



Curriculum Analysis Report

Manufacturing Skill Standards Council's
Curriculum for

**CERTIFIED TECHNICIAN –
SUPPLY CHAIN AUTOMATION
(CT-SCA) EQUIPMENT
MAINTENANCE**

February 2021

Table of Contents

Table of Contents	i
Executive Summary	1
Section 1.....	2
Curriculum Review	2
Section 2.....	4
Skill Analysis	4
Applied Math	5
Graphic Literacy	13
Workplace Documents.....	24
Section 3.....	30
Appendix A.....	31
Skill Descriptions.....	31
Appendix B	48
Learning Objectives	48

Executive Summary

The Manufacturing Skill Standards Council (MSSC) and ACT recognize the benefits to stakeholders of “stacking” MSSC certification credentials upon ACT’s WorkKeys Assessments, specifically the National Career Readiness Certificate (NCRC), as the “foundation” for MSSC’s Certified Technician–Supply Chain Automation (CT-SCA) for Equipment Maintenance, Certified Forklift Technician (CFT), Certified Production Technician (CPT), Certified Logistics Associate (CLA), and Certified Logistics Technician (CLT) credentialing programs. The results of the current project and review of its findings can help guide the selection of students into the CT-SCA Equipment Maintenance program and encourage skill development for those applicants whose skills currently do not match the recommendations for entry.

The WorkKeys curriculum profiling procedure is designed to identify the skills and the skill levels needed to enter and successfully complete a training program. When combined with the remaining components of the WorkKeys system, (i.e., the assessments, instructional support, and reporting), curriculum profiles provide educators with information regarding an individual’s readiness for training and provide individuals with the information they need to recognize the areas they may need to strengthen as they pursue their education and career goals.

The profile was conducted by ACT’s Industrial/Organizational Psychologist and profiler Cindy Hill, Ph.D. (Dr. Hill). The curriculum profiling procedure includes the following:

- A review of the curriculum materials available in the E-learning portal
- A skill analysis to 1) identify the WorkKeys skills required to accomplish each learning objective/standard, and 2) identify how the skills are used during the training program
- A skill level-setting to determine the skill levels recommended for entry into and for successful completion of the CT-SCA Equipment Maintenance online certificate modules

Skill Level Recommendations for Entry into and Exit from the CT-SCA Equipment Maintenance Curriculum

WorkKeys Skill	Skill Level Range	Entry	Exit
Workplace Documents	3-7	4	5
Graphic Literacy	3-7	4	5
Applied Math	3-7	4	5

Section 1

Curriculum Review

The first step in conducting the profile was to obtain background information on the program from the Manufacturing Skill Standards Council's representatives. This included obtaining the learning objectives/skills of the program which indicate the parameters and expectations of the program and its requirements.

The Certified Technician-Supply Chain Automation (CT-SCA) certification program is a national, industry-led, hands-on training and assessment program developed through collaboration with the National Science Foundation-funded National Center for Supply Chain Automation (NCSCA), the Manufacturing Skill Standards Council (MSSC), the Material Handling Equipment Distributors Association (MHEDA), the Material Handling Industry (MHI), and Amatrol. The goal of the CT-SCA certification program is to prepare technicians who install, operate, support, upgrade, and maintain the automated material handling equipment and systems which support the supply chain, and to raise performance of Technician-Supply Chain Automations, both to assist individuals in *finding higher paying jobs* and to help employers ensure their workforce is skilled. This combination increases the company's productivity and competitiveness. The CT-SCA credential will give technical and community college students the tools to enter career pathways within the material handling industry.

The first step in developing the certification program was for NCSCA to convene a meeting that involved 25 members of its Industry Leadership Team to define what a Supply Chain Automation Technician (SCAT) does. Next, it was critical to identify the skills these technicians need. Several meetings were held around the country to identify the skills technicians would need. The trade association MHI brought in many material handling suppliers to contribute their ideas. In addition, NCSCA invited companies that would employ the technicians in their distribution centers such as Target, Dollar Tree, FedEx Ground, Kohl's, and Walgreens. They each offered their input on the skills most needed. Dr. Katherine Manley, the head of the MSSC Certification Scheme Committee, lead this effort. Dr. Manley is an eminent authority on certifications and assessments. She is a graduate professor in the College of Education and Human Services at Ferris State University where she teaches courses on integrated curriculum development, test and measurement. She earned her doctorate at Virginia Tech in Vocational Education and has been a college administrator-both at a community college and as Assistant Vice President for Curriculum & Instruction at Ferris. She has also served as a research specialist at the National Center for Research in Vocational Education at The Ohio State University. The MSSC Certification Scheme Committee is required under ISO Standard 17024 (Personnel Certification) as the final authority on certification processes and Senior Advisor to the MSSC Board on all aspects of ISO accreditation.

The CT-SCA is comprised of three separate certificates that make up the full MSSC CT-SCA Certification program:

- Certification in Equipment Maintenance
- Certification in Equipment Repair

- Certification in Network Repair

Each of the three CT-SCA certifications requires students to attend 160 hours of classroom instruction, either in-class or online. A portion of those hours are dedicated to hands-on training using the Skill Boss Logistics system. Amatrol has developed three online, interactive, multimedia courses for the certifications. Students receive a certification by passing both the written and hands-on portions of the test for each certification. The Certification in Equipment Maintenance focuses on maintaining equipment and systems. This is broken down into 10 key activities and performance indicators. Examples include monitor machine/system operation, perform preventive maintenance and communicate with co-workers to promote productivity. Students are also instructed in 85 distinct technical knowledge areas and skills. Broad headings here range from machine operation and monitoring to preventive maintenance adjustments and service. Specific skill examples include knowledge of basic hydraulic, pneumatic and electrical principles and components.

Development of the Skill Boss Logistics system was also based on broad industry representation and input. The Skill Boss-Logistics hands-on training and assessment device is compact and transportable, can fit easily into any training environment, is cost effective, and shows students a variety of situations that they will come across during their career. Built by Amatrol, Skill Boss-Logistics draws upon 100 skills from MSSC's list of industry-defined and nationally validated CT-SCA Standards including rollers and belts, programmable logic controllers, robotics and other network devices. CT-SCA certificants must use this device for the hands-on training and assessments needed to secure any MSSC CT-SCA Certification.

The focus of this study was on the MSSC CT-SCA Certification in Equipment Maintenance.

Section 2

Skill Analysis

The skill analysis was conducted by ACT's Industrial/Organizational Psychologist and profiler Cindy Hill, Ph.D. (Dr. Hill). Dr. Cindy Hill has been an Industrial/Organizational Psychologist in the Research Division at ACT, a mission-driven, non-profit organization dedicated to helping people achieve education and workplace success, since 1996. Her work has included the recent refresh of the National Career Readiness Credential, a portable, evidence-based credential that certifies the essential skills for workplace success. Dr. Hill has been a major contributor to the design and presentation of the WorkKeys Profiling Training Program. She managed the development and implementation of the WorkKeys 7-week profiling training program, which includes paper-based and web-delivered distance learning activities and a face-to-face on-site workshop. Dr. Hill has trained hundreds of people to conduct ACT WorkKeys profiles and provides coaching and support for all profilers. She has worked directly with many different types of service and manufacturing industries including medical, food processing, utilities, music distribution, telecommunications, chemical processing, and oil. For example, her projects have included working with the plastics molding division of a Fortune 200 company with revenue exceeding \$3 billion annually, an agribusiness Fortune 100 company, two chemical processing Fortune 100 companies, and with an international corporation that is one of the largest producers of beverage products. Her recent research has explored the alignment and "stacking" of credentials through standardized frameworks and the use of technology. Dr. Hill has also spent many years developing and reviewing licensure and certification programs. This includes job analysis, the development of test content outlines, national surveys, data analysis, item writing and review, standard setting, and validating the test scores of off-the-shelf and company-specific tests. As part of ACT's partnership with the Association for Talent Development, she developed and facilitates their Test Design and Delivery Certificate Program. This program assists learning professionals to develop valid tests for training, certification, and management decision-making.

The curriculum profiling procedure includes the following:

- A review of the curriculum materials available in the E-learning portal
- A skill analysis to 1) identify the WorkKeys skills required to accomplish each learning objective/skill, and 2) identify how the WorkKeys skills are used during the training program
- A skill level-setting to determine the WorkKeys skill levels recommended for entry into and for successful completion of the CT-SCA Equipment Maintenance certificate modules.

APPLIED MATH

WorkKeys Applied Math is the skill people use when they use mathematical reasoning and problem-solving techniques to solve work-related problems. Employees may use calculators and conversion tables to help with the problems, but they still need to use math skills to think them through. Dr. Hill identified 19% of the learning objectives/skills as requiring the WorkKeys Applied Math skill.

In evaluating the level of Applied Math skill necessary for the student to master the learning objectives/skills of the curriculum, the types of mathematical operations (including single-step or multiple-step mathematical operations and conversions either within or between systems of measurement); how the information in the problem is presented (i.e., the information is presented in the order in which it is needed or it must be reordered); and whether all the information employees need for solving problems is provided or if they must derive some necessary information that must be considered.

Dr. Hill evaluated the curriculum in comparison to WorkKeys Applied Math skill levels 3 through 7 and determined that Level 4 skills are required for entry into the curriculum. Students are expected to apply their math skills to specific situations during the training program, so they need to begin the program with Level 4 Applied Math skills. By the end of the program, students should have Applied Math Level 5 skills and may have mastered some Level 6 and Level 7 Applied Math skills.

At Applied Math Level 4, learning objectives/skills may present information out of order and may include extra, unnecessary information. One or two operations may be needed to solve the problem. A chart, diagram, or graph may be included. When employees use Level 4 Applied Math skills, they can solve problems that require one or two operations. They may add, subtract, or multiply using positive or negative numbers, and they may divide positive numbers. They can figure out an average or mean of a set of numbers using whole numbers and decimals. They can figure out simple ratios, simple proportions, or rates. At Level 4 employees can add commonly known fractions, decimals, or percentages and add or subtract fractions that share a common denominator. They can multiply a mixed number by a whole number or decimal and they can put the information in the right order before they perform calculations.

Students are introduced to dimensional measurement in Unit 6. This is the first time in the training that math skills are needed. In module 6.2, they are introduced to the US Customary and Systems International measurement systems for distance or length and shown how to count using a machinist scale. They are expected to understand the concept of fractions and are shown how to read $\frac{1}{16}$ and $\frac{1}{32}$ on the machinist scale. In module 6.6, they are shown how to reduce a fraction by dividing the numerator and denominator by 2 until the number is odd. Students will need Level 4 Applied Math skills prior to this module in order to understand how to work with fractions.

In Unit 7: Caliper Measurement, students are taught how to calculate a dial caliper reading using addition (Measurement = Scale + Dial). In Unit 8, students are taught the micrometer measurement formula that requires them to add numbers (Total Measurement = B + S + T + V). Students are using WorkKeys Applied Math Level 4 skills when they put the information into the formula in the right order before they perform the calculations and when they multiply a mixed number by a whole number or decimal. When students learn about mechanical power in Unit 11, they are introduced to units of mass or weight and that 1 kilogram = 1,000 grams. The following formulas are introduced to students and students are shown how to calculate using the US and SI systems and then provided with guided practice:

- Force = Mass x Acceleration
- Work = Force x Length
- Power = Force x Velocity (speed)
- Hooke's Law: Force Applied to the Spring = Hooke's Constant or Spring Rate x Distance the Spring is Compressed or Extended

In Unit 12: Basic Mechanical Elements, students are introduced to the formula for torque and are provided with an explanation, an example, a diagram showing the application, and then step-by-step directions on how to insert the known values into the formula and calculate the result (shown in Figures 1 and 2).

Figure 1: Formula for Torque



Figure 2: Steps to Calculate Torque

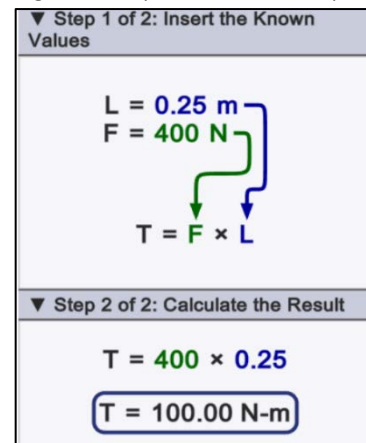

The formulas to this point only require addition or multiplication. In module 12.4, students are introduced to the Mechanical Advantage formula (see Figure 3) and it requires students to understand ratios. While the lesson demonstrates how to insert the known values into the equation to set-up the ratio (see Figure 4), it does not teach them how to perform the math calculation to find the result. Students need WorkKeys Level 4 Applied Math skills when entering the training in order to figure out simple ratios, simple proportions, and rates.

Figure 3: Formula for Mechanical Advantage

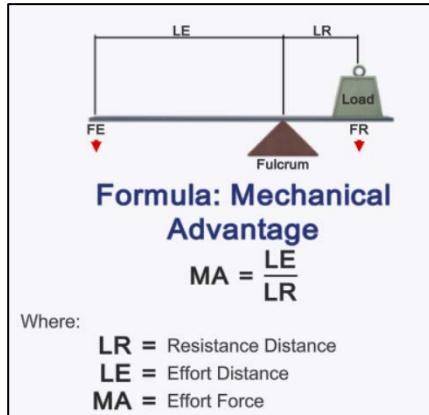
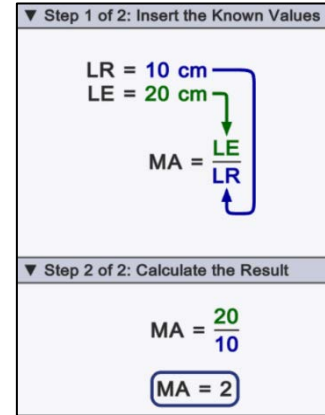

Figure 4: Steps to Calculate Mechanical Advantage



Additional formulas introduced in Units 12 through 23 include:

- Force Output
- Power
- Power Efficiency
- Gear Ratio
- Gear Ratio with teeth
- Sprocket Ratio
- Chain Drive Speed
- Chain Drive Torque
- Torque vs Sprocket Ratio
- Sprocket Ratio Calculation Interaction
- Belt Drive Ratio
- Belt Drive Speed (Driven Speed Calculation)
- Sheave Torque
- Kirchhoff's Voltage Laws
- Voltage Drop

In Unit 24, students are introduced to the formula for Equivalent Resistant Parallel Loads (see Figure 5) and are expected to work with complex fractions (i.e., reciprocal resistance becomes the denominator in the fraction). While the students are shown how to insert the values and provided with the solution, they are not taught how to add a fraction or simplify it. For this reason, students need WorkKeys Applied Math level 4 skills when entering the program. By this point in the training, the students

Figure 5: Equivalent Resistant Parallel Loads Formula

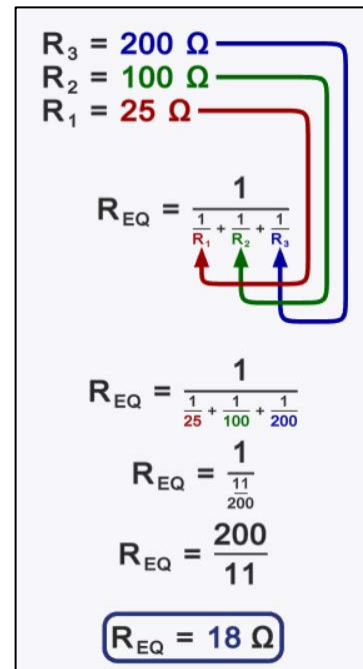

have had the opportunity to master several WorkKeys Applied Math level 5 and 6 skills including solving problems when the information may not be presented in a logical order, the item may contain extraneous information and/or chart, graph or diagram; and the mathematical set-up may be complicated. In solving, the student may need to perform multiple operations, deciding what information, calculations, or unit conversions to use to find the answer to a problem, adding and subtracting fractions with unlike denominators, finding one value and using it to find another value in a multiple step problem, and solving problems that require mathematical operations using mixed units.

In Unit 24: Electrical Resistance Measurement, students will be taught how to apply Ohm’s Law when troubleshooting circuits, calculating power needs, sizing components, creating multiple voltage levels, and solving for voltage, current, resistance, and parallel and series circuits. In Unit 25: Power in Electrical Circuits, they will learn to apply the Power Law ($P = I \times E$) and its alternate forms, as well as how to combine it with Ohm’s law. Unit 26 covers inductance and provides a mathematical example of an inductor application in a DC automotive ignition circuit and Ohm’s Law. Being able to identify the correct equation to solve a problem is a WorkKeys Level 6 Applied Math skill. In Unit 26, students are introduced to Pi (π), working with an irrational number, when they use the Inductive Reactance formula. However, they are simply taught to use the number 3.1416 as the value for Pi. They aren’t required to understand the importance of irrational numbers. As shown in Figure 6, the concept of tolerance is introduced in Unit 27: Capacitance. Being able to interpret statistical concepts such as tolerance and spread is a Level 7 WorkKeys Applied Math skill. Students encounter Pi when presented with the Capacitive Reactance Formula (Figure 7) in this unit, but this time it is in the denominator of the equation and they may have to convert units. This also requires Level 7 Applied Math skills.

Figure 6: Excerpt from Unit 27 on Tolerance

Electrolytic capacitors provide the most capacitance in the smallest space and at the least cost.

They are available with capacitance values ranging from $10\mu\text{F}$ to thousands of μ farads. Electrolytics are used in most DC power supplies to provide a smooth DC output level.

Since they are most often used in filtering applications, their tolerances fluctuate widely. Larger electrolytic capacitors have typical tolerances of -10 to +50%, meaning that a $10,000\mu\text{F}$ capacitor has an actual value that can range from 9,000 to $15,000\mu\text{F}$.

Figure 7: Capacitive Reactance Formula

Branch Part 2

Capacitive Reactance Formula

$$$X_c = \frac{1}{2\pi fC}$$$

$f = 60 \text{ Hz}$

$C = 0.000000010 \text{ F}$
(same as $0.01 \mu\text{F}$)

$X_c = 265, 258 \text{ Ohms}$

NOTE: You must use farads in the equation as presented. To use microfarads you would have to include the appropriate conversion factor.

In Unit 28: Combination Circuits, the math becomes very complex because there are multiple unknowns that must be solved for. Solving a circuit involves determining unknown values of resistance, current, or voltage in a combination circuit. There are seven general steps, but the

order may have to be altered depending on the information given for the circuit. Givens are shown in Figure 8 and 27 steps later the solution is shown in Figure 9.

Figure 8: First Step in Solving a Combination Circuit

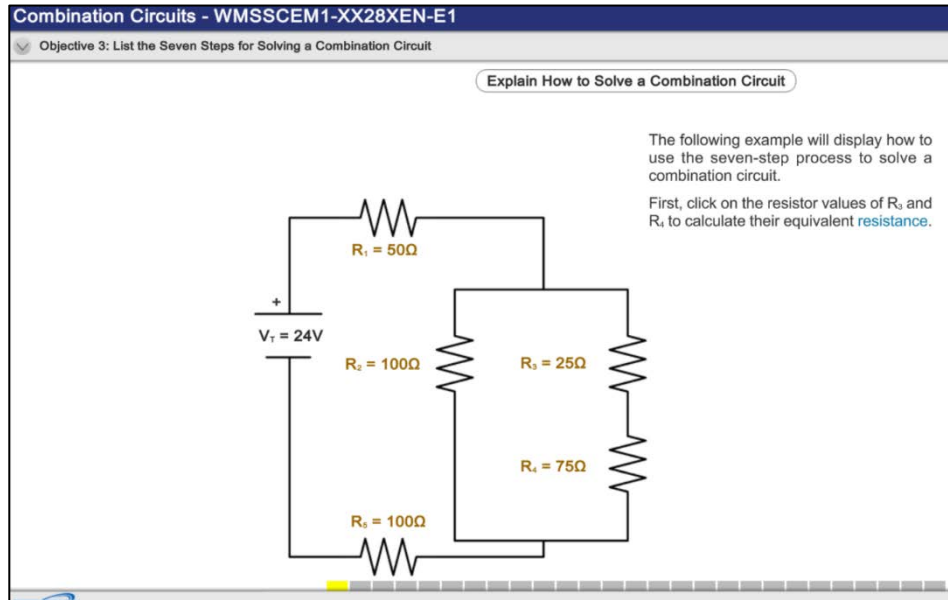
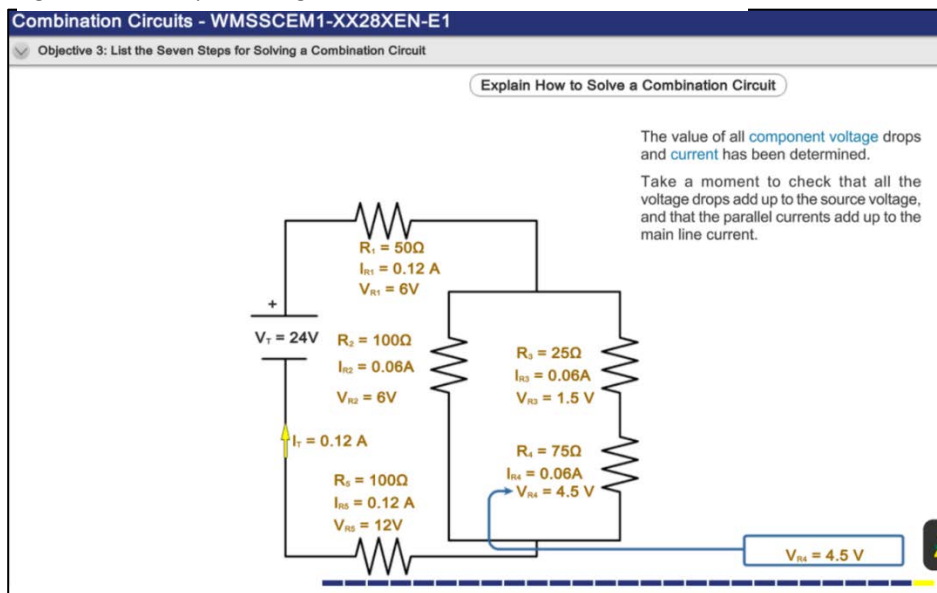

Figure 9: Final Step in Solving a Combination Circuit



Next, the students are expected to solve a combination circuit on their own. However, the lesson does walk them through the process by providing the image, given information, and the formula for each step. It also includes an indicator of where they are in the process on the far-right hand side of the screen (Figure 10). The student must attempt an answer at least three times before they can access the solution for that step.

Figure 10: Guided Practice for Solving a Combination Circuit

The screenshot shows an online calculation interface for a combination circuit problem. The interface is titled "Combination Circuits - WMSSCEM1-XX28XEN-E1" and "Skill 2: Solve a Combination Circuit". It features a navigation bar with tabs for "Image", "Given", "Formula", and "Solution". The main content area displays a circuit diagram with a 24V DC source, a 25Ω resistor, a 50Ω resistor, and a 25Ω resistor in series with a parallel branch containing a 50Ω resistor and a 75Ω resistor. The interface includes a question: "Resistance of Parallel Branch" and "What is the equivalent resistance of the first parallel branch of the circuit? Round your final answer to the nearest hundredth." A text box is provided for the answer, labeled "R₂₃ =".

Unit 29: Voltage Dividers includes the Stiff and Firm Voltage Divider formula. Students will need to use WorkKeys Applied Math Level 6 skills when they must rearrange the formula in order to design a voltage divider network for three scenarios. In Unit 30, students will be asked to use the Turns Ratio formula and Transformer Output Voltage formula in order to calculate the output voltage and the secondary coil voltage of a transformer. The Steady-State VA formula and Max. In-Rush VA formula is used to size a transformer and the Transformer Efficiency formula is used to determine the amount of heat generated and ventilation needed for a transformer to operate efficiently. Students will need Level 5 and 6 skills to perform tasks using these formulas because they must choose the correct formula, perform multiple calculations, and may need to rearrange the formula depending on the information given.

Students will learn how to use the Pressure Formula in Unit 33: Introduction to Fluid Power, but this formula only requires simple division. However, students will need higher level Applied Math skills to convert pressure units from SI to US or US to SI and understand range and tolerance when reading a pressure gauge. In Unit 36: Hydraulic Power, students will need to be able to calculate volumetric flow rate using a formula. Unit 39: Fluid Force and Friction requires students to understand the difference between absolute and gauge units of pressure measurement and how to convert from one to the other. Students will also be using Applied Math Level 6 skills when calculating the force output of a cylinder during extension in SI and US units (Figure 11). The students first calculate the area of the bore (i.e., circle) and then use the result in further calculations. They will use Level 7 skills when using the Combined Gas Law (Figure 12). This formula requires them to calculate the initial volume and final volume of a container in order to determine the effects of temperature.

Figure 11: Extending Cylinder

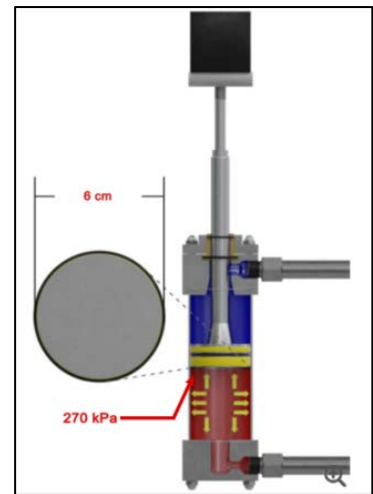

Figure 12: Combined Gas Law

Combined Gas Law

$$\frac{P_1 \times V_1}{T_1} = \frac{P_2 \times V_2}{T_2}$$

Where:

- T_2 = Final Absolute Temperature (°R/K)
- V_2 = Final Volume
- P_2 = Final Absolute Pressure (psia/kPa absolute)
- T_1 = Initial Absolute Temperature (°R/K)
- V_1 = Initial Volume
- P_1 = Initial Absolute Pressure (psia/kPa absolute)

Volumes may be stated either in in³, ft³, cm³, or m³. Whichever is used, both volumes must be expressed in the same unit.

By the time students have completed all forty units, they will have many of the Applied Math Level 6 skills. At Applied Math Level 6, tasks may require considerable translation from verbal form to mathematical expression. They generally require considerable setup and involve multiple-step calculations. When employees use Level 6 Applied Math skills, they can use fractions with unlike denominators and calculate reverse percentages.

They can convert units within or between systems of measurement where multiple-step conversions are required, and the formulas are provided such as converting from kilometers to meters to feet. They can identify why a mistake occurred in a solution. Employees can find the best deal and use the result for another calculation. They can find the area of basic shapes (rectangles and circles) when it may be necessary to rearrange the formula, convert units of measurement in the calculations, or use the result in further calculations. At Level 6 employees can find the volume of rectangular solids. They can calculate rates, productions rates, and rate by time. They can identify the correct equation for solving a problem.

Students will also have some Applied Math Level 7 skills. At Applied Math Level 7, the task may be presented in an unusual format and the information presented may be incomplete or require the employee to make an assumption. Tasks often involve multiple steps of logic and calculation, and multiple operations. When employees use Level 7 Applied Math skills on the job, they can solve problems that include ratios, rates, or proportions with at least one of the

quantities related to a fraction. They can identify the reason for a mistake. They can convert between units of measurement that involve fractions, mixed numbers, decimals, or percentages. Employees can find the area of multiple shapes or find the area of a composite shape. They can calculate volumes of spheres, cylinders, or cones. They can calculate the volume when it may be necessary to rearrange the formula, convert units of measurement in the calculations, or use the result in further calculations. At Level 7 employees can set up and manipulate ratios, rates, or proportions where at least one of the quantities is a fraction. They can determine the better economic value of several alternatives by using graphics or by finding a percentage difference or a unit cost. They can apply basic statistical concepts, for example, calculate the weighted mean, interpret measures of central tendency, or interpret measure of spread and tolerance. While students may have some Level 6 and Level 7 skills by the end of the program, they should have mastered Level 5 Applied Math skills.

GRAPHIC LITERACY

The WorkKeys Graphic Literacy skill is the skill people use when they work with workplace graphics such as tables, graphs, charts, digital dashboards, flow charts, timelines, forms, maps, and blueprints. Students use this skill when they find, summarize, compare, and analyze information to make decisions using workplace graphics to solve work-related problems. Dr. Hill identified 85% of the learning objectives as requiring the WorkKeys Graphic Literacy skill for entry into and successful completion of the training program.

In evaluating the level of Graphic Literacy skill needed to accomplish the learning objectives/skills of the curriculum, the difficulty of the graphics and how hard it is for individuals to find the information they need on the graphic and then to make use of it was considered. Dr. Hill compared the requirements of the training program to WorkKeys Graphic Literacy skill Levels 3 through 7. Level 4 Graphic Literacy skills are required for entry into and for successful completion of the training. By the completion of the training, students will have Level 5 Graphic Literacy skills and some Level 6 and 7 skills.

At Graphic Literacy Level 3, workplace graphics are common and of simple or low moderate difficulty. Characteristics of simple graphics include a limited amount of data (i.e., less than twenty data points/fields); one level of data; one or two variables; and one or two axes (such as an x and/or y axis), if there are axes. Characteristics of low moderate graphics include a moderate amount of data; more than one level of data, but no nesting; several variables; one or two axes if there are axes; and if two simple graphics are required to solve the problem, they should be considered a low moderate graphic. At Graphic Literacy Level 3, students use one simple or low moderate graphic at a time to locate and find information and identify the next or missing step in a process.

Students will use Graphic Literacy Level 3 skills throughout the training when they are shown various diagrams and asked to identify and describe various parts. For example, students may be shown a diagram of an air filter (Figure 13) and then asked to identify the specific parts and how they operate. In some instances, the diagrams are animated. For example, students will be shown an animated diagram of a 5-Port, 3-Position DCV function directional control valve. They will then be expected to identify and describe how each of the 3 positions creates a different flow pattern between each of the five ports.

Figure 13: Air Filter Components Diagram

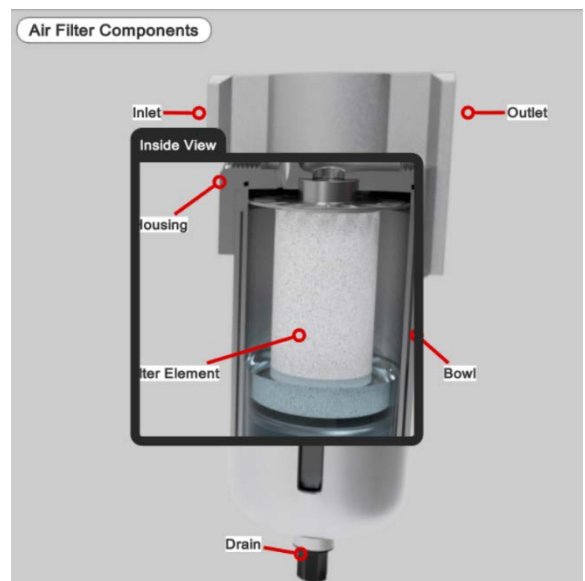

Students will also use Graphic Literacy Level 3 skills when they locate information in tables or complete forms that are of simple or low moderate difficulty. The Job Hazard Analysis sample

worksheet shown in Figure 14 is an example of a form they may need to learn to complete, and they may need to determine what action to take after locating information in a digital work order like the one shown in Figure 15.

Figure 14: Example of a Job Hazard Analysis Worksheet

Job Hazard Analysis Worksheet			
Title of Operation		SOP/SWP No:	
Position/Title: (Person who does the job)		Building:	
Department:		Section:	
Basic Steps	Potential Hazards	Procedure to Be Followed (DOs)	Safety Precautions (if procedure does not fully control risks) (DON'Ts)
Prepared by:		Date:	
Approved by:		Date:	
H&S Rep/Committee Reviewed:		Date:	
Next Review Date < 5 yrs:			

Figure 15: Digital Work Order

Work Order	Priority	Equipment	Description	Status	Submit Date	Completed Date	Mechanic
1190	3: Standing Work Order	Compressor Filter	Check/Replace Filter	Complete	2015-08-07	2015-08-07	Allen
1187	2: ASAP	MB	Replace Bulb	Pending Approval	2015-08-12		
978	1: Immediate Safety Production Down	Band Saw	Replace Blade	Complete	2015-07-21	2015-07-21	Garda
1052	4: No Priority	Compressor	Test Belt Tension	Pending Approval	2015-08-01		
1101	4: No Priority	Drill Press	Clean Internal Components	Pending Approval	2015-08-29		

Figure 16: Selecting the Appropriate Wrench Size

US Customary	
Bolt Diameter (Inches)	Head/Wrench Size (Inches)
1/4	7/16 or 3/8
5/16	1/2
3/8	9/16
7/16	5/8
1/2	3/4
9/16	—
5/8	15/16
3/4	1-1/8
7/8	1-5/16
1	1-1/2

Metric	
Bolt Diameter (mm)	Head/Wrench Size (mm) ANSI/ISO
4	7
5	8
6	10
7	—
8	13
10	16
12	18
14	21
16	24
18	—

Students will work with many tables throughout the curriculum. The two tables shown in Figure 16 are examples of simple two column tables students use to select the appropriate

wrench size. Additional simple and low moderate tables and forms that require students to use Level 3 Graphic Literacy skills include the following:

- Standard Operating Procedures
- Preventative Maintenance Schedules
- Sizing Circuit Protection table for selecting a fuse (3 columns with more than 30 fields)
- Course Thread Series table (four columns with 32 fields)
- Part Measurements table (two columns with ten fields)
- Viscosity of SAE Lubricants at 100°F table (three columns with 21 fields)
- Oil Viscosity List (four columns with 40 fields)
- Grease Categories table (two columns with 14 fields)
- Grease Selection table (four columns with 40 fields+)
- Material Reflectivity Chart (two columns with 10 rows)
- Fluid Power Feature Comparison table (three columns with 9 rows)
- Transformer Electrical Specifications and Ordering Data (Supply Voltage 222VAC) table (seven columns)

Knowledge Checks often present the student with a diagram and ask the student to drag and drop labels into the correct location. In Unit 1, students are shown a simple diagram of Distribution Center Automation and asked to drag and drop five pictures to the correct location (Figure 17).

Figure 17: Knowledge Check Example of Drag and Drop using a Diagram

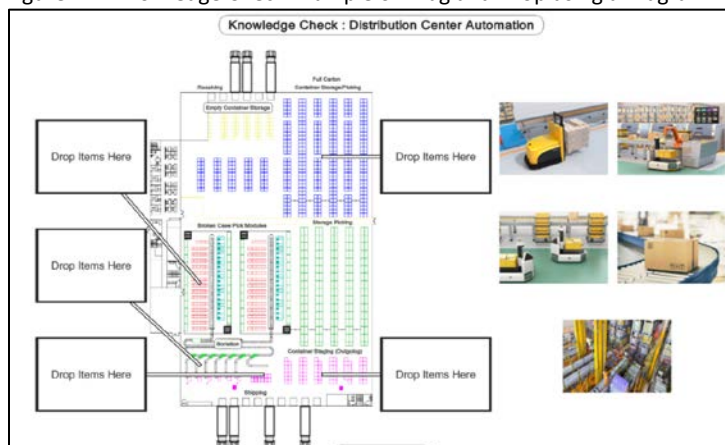

Knowledge Checks also present students with three to five bins or categories and ask students to place five to ten items in the correct bin. An example is shown in Figure 18.

Figure 18: Knowledge Check Example of Drag and Drop Items into Bins

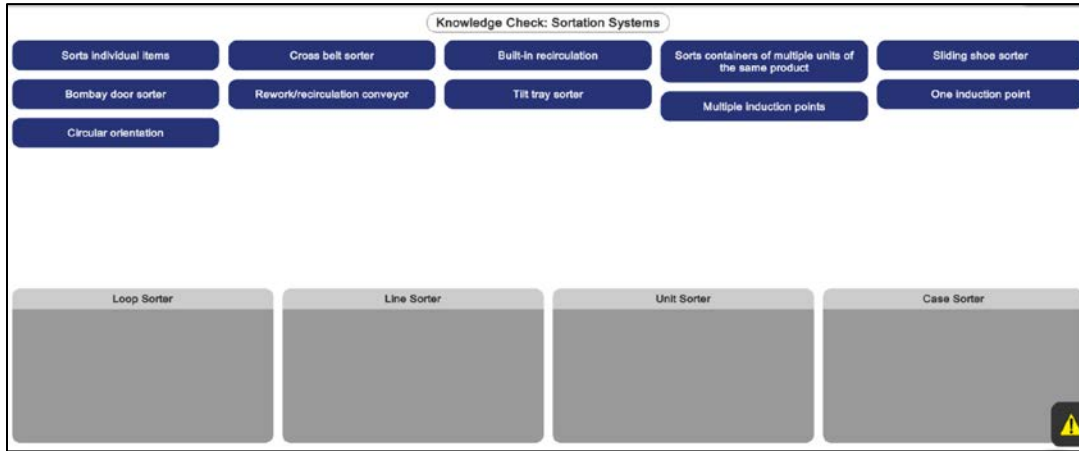

Knowledge checks will also ask students to label parts of a tool or device as shown in Figure 19.

Figure 19: Knowledge Check Drag and Drop for a Gauge

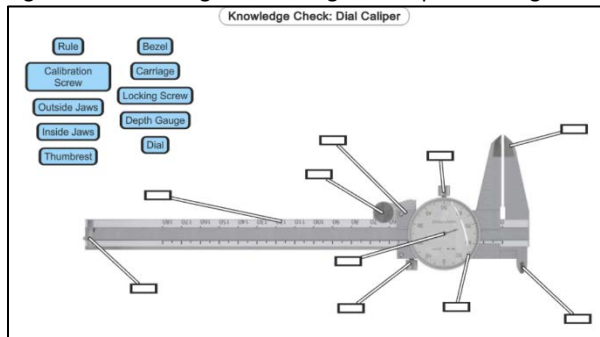

Most of the graphics students use require Level 4 Graphic Literacy skills. At Graphic Literacy Level 4, workplace graphics are common and of low to high moderate difficulty. Characteristics of low moderate graphics include a moderate amount of data; more than one level of data, but no nesting; several variables; one or two axes, if there are axes; and if two simple graphics are required to solve the

problem, they should be considered a low moderate graphic. At Graphic Literacy Level 4, students can use one or two low moderate graphics at a time to locate information in a graphic using information found in another graphic; compare two or more pieces of information; identify a

trend/pattern/relationship; make an inference or decision; and identify the graphic that accurately represents the data. High moderate graphics may be less common at Graphic Literacy Level 4 and have characteristics which include a moderate amount of data; more than one level of data and it may be nested; many variables such as types of wood, drill speeds, hole diameter, and type of bit; one or two axes (such as an x and/or y axis), if there are axes; and if a low moderate graphic and a simple graphic are

Figure 20: Pulley Diameter and Deflection Force Table

Pulley Diameter and Deflection Force				
Belt Type	Smallest Sheave Diameter (mm)	Range (rpm)	Belt Deflection Force (kg)	
			Used Belt	New Belt
SPZ	50 to 79	1000 to 2500	1.7	2.7
		2501 to 4000	1.3	2.2
	80 to 95	1000 to 2500	2.0	3.7
		2501 to 4000	2.1	3.3
95 and Over	1000 to 2500	2.4	3.7	
	2501 to 4000	2.2	3.4	
SPA	71 to 105	1000 to 2500	2.9	4.4
		2501 to 4000	2.7	4.0
	106 to 140	1000 to 2500	3.6	5.3
		2501 to 4000	3.2	4.8
141 and Over	1000 to 2500	4.5	6.8	
	2501 to 4000	4.5	6.7	
SPB	107 to 159	860 to 2500	5.0	7.5
		2501 to 4000	4.8	7.2
	160 to 250	860 to 2500	6.4	9.6
		2501 to 4000	5.7	8.6
250 and Over	860 to 2500	7.7	11.4	
	2501 to 4000	6.5	9.8	
SPC	200 to 355	500 to 1740	10.4	15.5
		1741 to 3000	10.5	15.7
	356 and Over	500 to 1740	11.8	17.6
		1741 to 3000	13.7	20.4

required to solve the problem, they should be considered a high moderate graphic. At Level 4, students can use one high moderate graphic to locate and find information and identify the next or missing step in a process.

Students will use Level 4 Graphic Literacy skills when they use a manufacturer's table to identify the proper tension setting for a belt. An example is provided in Figure 20. This table is of high moderate difficulty because it contains multiple variables and range is nested within smallest sheave diameter, and smallest sheave diameter is nested within belt type. In addition, the type of belt (used or new) is nested within belt deflection force. However, students are only required to locate information, so Graphic Literacy Level 4 skills are enough.

Students will also work with a high moderate table when they are troubleshooting a vacuum cup. The chart shows how to troubleshoot problems by identifying the system and possible cause and then deciding how to test and remedy the problem. Students will also need to be able to complete charts with test results that include nesting and then make predictions and decisions about what to do next. Additional high moderate tables students will need Graphic Literacy Level 4 skills to work with include Circuit Breaker Ordering Data table (four columns with nesting) and the Common Bolt Size table (three columns with more than 20 fields and with nesting for pitch).

Students will learn how to use Human Machine Interface panels with multiple screens. For example HMI screens in sortation systems may be programmed with the following screens: main, alarm, manual operation monitoring, order entry, and schematics and other supporting information. Students need to identify the correct field to move from one screen to another (e.g., "To place system in automatic mode, users should select the Main option from the menu screen, then press the System Start button."). Graphic Literacy Level 4 skills are required because the information presented on the screens is not common, the students have to decide which screen is the best one to use for a particular task, and are often required to compare information from one screen to another in order to make a decision on how to proceed. A sample screen is shown in Figure 21.

Figure 21: Example of an HMI screen



Students will be shown many graphics, diagrams and pictorials. Some are simple or of low moderate difficulty. The students will use Graphic Literacy Level 3 skills to locate components and recognize differences or relationships between diagrams showing different designs such as diagrams showing four types of picking methods (e.g., single order, bath, zone, and pick and pass). Some examples of the graphics, diagrams, and pictorials students will use include:

- Cross-dock
- Bulk-break facility
- Distribution Center Automation
- Cycle Time
- Evaluation plan
- Hydraulic System Components
- Belt Conveyor Components
- Bearing Types
- Pneumatic system components including types of control valves
- Pressure regulator valve function
- Basic Cylinder components
- Double-acting hydraulic cylinder components
- Lever Components for first, second, and third-class levers
- Hydraulic Pump
- Pressure gauge tee fittings
- Circuit
- Meter-out control circuit

However, some diagrams and pictorials are more complex, and students need to be able to understand the relationship or effect of one component on another such as how the sheave size

effects the amount of torque delivered to the load (Figure 22). Using this understanding, students will need to be able to make decisions regarding the correct sheave size needed. This requires Graphic Literacy Level 4 skills.

Figure 22: Sheave Size Effect Diagram

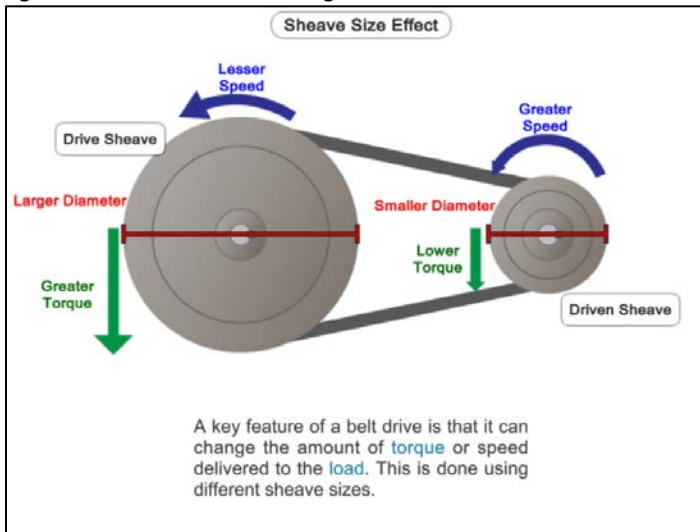

Additional graphics requiring students use WorkKeys Graphic Literacy Level 4 skills to understand how to apply a concept in order to interpret results, identify relationships or trends, or make decisions regarding the appropriate action to be taken include the following:

- Potential Energy
- Effect of force Direction
- Power Conservation Impact: Gearbox example
- Static Friction
- Energy Storage Applications: Flywheel example
- Shaft/Bearing Assembly Application
- Pitch Diameter
- Straight Edge Alignment Check
- Tension Tester Adjustment
- DC Power Supply Applications
- Constant Current Supply
- Capacitor Construction
- Commercial Building Lighting System showing switches in combination circuits
- Magnetic Reed Switch diagram of application
- Basic Photoelectric sensor with three components, application and schematic for different types of sensors
- Sensor Transistor outputs
- Pneumatic Power Diagram demonstrating the concept

Students will learn to identify the appropriate devices for a task, the components of a device and how to use the device to perform a task. Graphic Literacy Level 3 skills are required when students are being introduced to a device. They will be shown a picture and various components will be identified as shown in Figure 23 of a digital multimeter to measure voltage.

Figure 23: Components of a digital multimeter



Students will then be shown how to connect a digital multimeter in order to measure voltage as shown in Figure 24.

Figure 24: Measuring Voltage with a Digital Multimeter

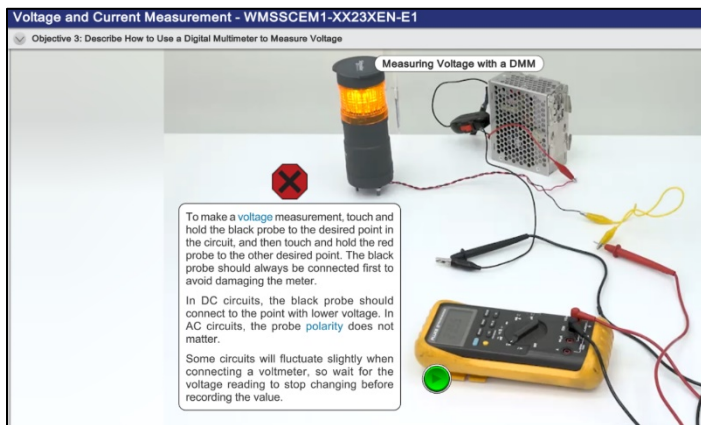

Finally, students will be expected to practice using a digital multimeter to measure voltage in the simulator. The students are required to follow the simulation directions to recreate the picture shown in Figure 25 in the simulator and the directions shown in Figure 26 that includes a schematic. The students are using Level 5 WorkKeys Graphic Literacy skills when they locate information in the schematic using information found in the pictorial.

Figure 25: Instructions for simulator

SKILL 2 USE A DMM TO MEASURE VOLTAGES IN SERIES AND PARALLEL CIRCUITS

1. Connect the series circuit shown in figure 2-1 and figure 2-2.

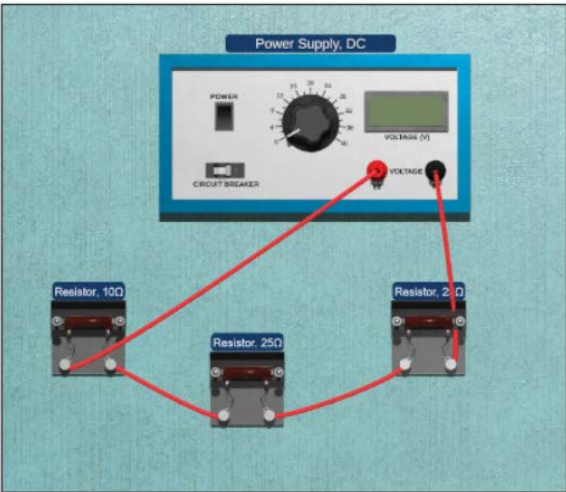

Figure 2-1. Pictorial of a 3-Resistor Series Circuit

Figure 26: Simulation Instructions for using a digital multimeter to measure DC voltage

2. Place a DMM on the workspace and prepare it to measure DC voltage.
Remember, set the scale to the largest possible value when measuring unknown values.

3. Turn on the power supply and set the voltage to 16 volts.

4. Perform the following substeps to measure the voltage across each resistor.

A. Measure the DC voltage across resistor R_1 by placing the multimeter probes on each side of the resistor. The schematic is given again in figure 2-3.

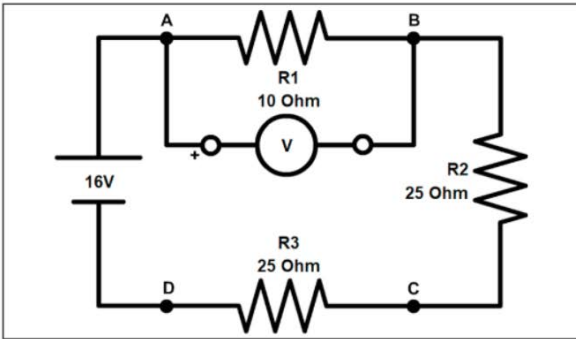

Figure 2-3. Schematic of 3-Resistor Series Circuit

Make sure the red test lead from the DMM is connected to the side of the resistor connected to the positive (+) terminal of the power supply and place the black test lead on the other side of R_1 .

B. Adjust the voltage range on the DMM until you reach the lowest voltage range that is still above the reading on the meter.

C. Record the voltage across resistor R_1 .

R_1 Measured voltage = _____ (VDC)
It should be approximately 2.7 VDC.

Students will learn about measurement beginning in Unit 6: Dimensional Measurement. Students will learn about the reference plane, width, height, depth, and diameter and how to read rulers with the US customary system and Systems International system. Students will learn how to read gauges such as a pressure gauge with psi and kPa scale major and minor graduations (Figure 27). They will also learn how to use flow meters and a machinist's rule.

Figure 27: Example of a gauge

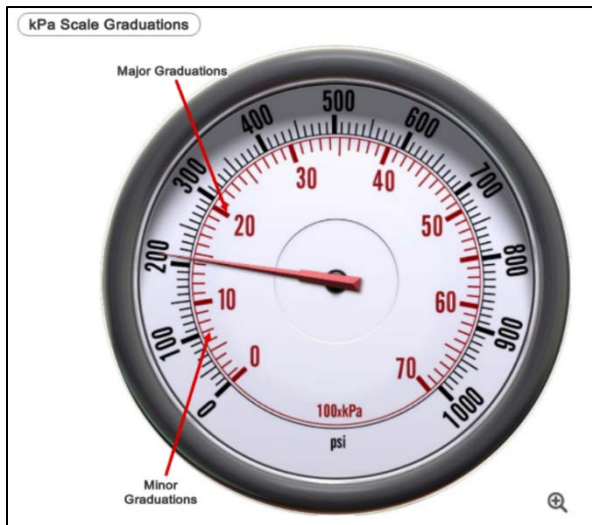

Students will learn how to read and use electrical schematic diagrams including AC Power Supply, DC Power Supply, Ground, Switch, Pushbutton, Lamp, and Motor. The electrical schematic diagram is a form of visual shorthand where each component is represented by a standard symbol. A schematic diagram represents the components in a circuit and how they are connected. Students are taught the basic schematic symbols and provided with step-by-step instructions teaching students how to read one (Figure 28).

Figure 28: Interpreting basic circuit flow

Basic Electrical Circuits - WMSSCEM1-XX21XEN-E1

Objective 5: Describe How to Interpret a Basic Electrical Schematic

Interpreting Basic Circuit Flow

To read a basic schematic, start with the power supply's positive terminal and follow the conductor path through the components to the negative terminal.

As you follow the path, identify the input and output devices. The output devices do the work and the input devices control when that work is done.

A switch is an input device that is in line with the output device to control its operation. The same power flows through each device, so all inputs must close in order for the output to turn on.

Students will be introduced to more advanced symbols and schematics. For example, electrical parameters will be introduced such as voltage, current, resistance values, selector switch schematic symbols for normally open contacts and normally closed contacts, knife switch, contrast double pole, and double throw symbols. Students will also be introduced to schematics including:

- Series and parallel circuits
- Schematic for troubleshooting can include voltmeter

- Equivalent resistance of parallel loads
- Schematic showing how to calculate power of multiple loads
- Series-Parallel Circuit Description
- Combination circuit schematic used to trace the current path
- Voltage Divider Network schematics for three types (i.e., firm, stiff, and loaded) and examples of applications
- Magnetic Reed Switch

Schematics will become much more difficult when students begin learning how to use a schematic of a circuit in order to troubleshoot and when they need to interpret branch system operations as shown in Figure 29. They will need Graphic Literacy Level 5 skills and possibly some Level 6 and 7 skills.

At Graphic Literacy Level 5, workplace graphics may be less common and of low moderate, high moderate, or difficult complexity. Characteristics of low moderate graphics include a moderate amount of data; more than one level of data, but no nesting; several variables; one or two axes, if there are axes; and if two simple graphics are required to solve the problem, they should be considered a low moderate graphic. At Level 5 Graphic Literacy, employees can use a low moderate graphic to compare two or more pieces of information; interpret a trend/pattern/relationship; make a reasonable inference or decision based on one graphic after finding information in another graphic; justify a decision or inference based on information; identify the most effective graphic for the task; and justify the most effective graphic for the task. High moderate graphics may be less common at Graphic Literacy Level 5 and have characteristics which include a moderate amount of data; more than one level of data and it may be nested; many variables; one or two axes if there are axes; and if a low moderate graphic and a simple graphic are required to solve the problem, they should be considered a high moderate graphic. At Level 5 Graphic Literacy, employees can use one high moderate graphic to locate information in a graphic using information found in another graphic; compare two or more pieces of information; identify a trend/pattern/relationship; make an inference or decision; and identify the graphic that accurately represents the data. Difficult graphics at Graphic Literacy Level 5 are likely to be less common or a composite of graphics. Data presented is dense; more than one level of data and nesting is likely; there are many variables such as types of wood, drill speeds, hole diameter, and type of bit; three or more axes, such as an x, y, and z axis, if there are axes; and if a high moderate graphic and a low moderate graphic are required to solve the problem, they should be considered a difficult graphic. At Level 5, employees can use one difficult graphic to locate and find information and identify the next or missing step in a process.

Figure 29: Interpret Branch System Operations

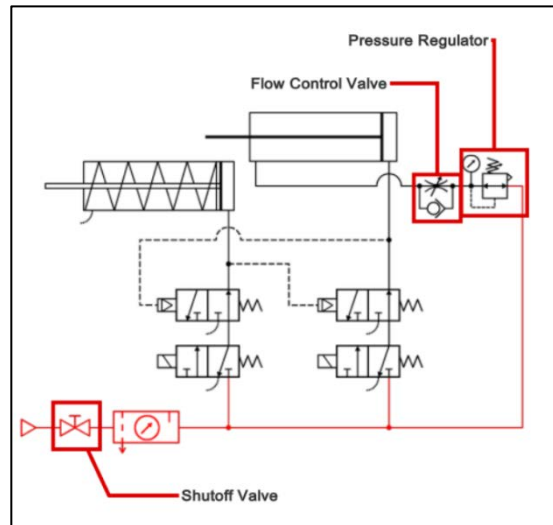

WORKPLACE DOCUMENTS

WorkKeys Workplace Documents is the skill people use when they read and use written text in order to do a job. The written texts include memos, letters, directions, notices, bulletins, policies, and regulations. It is often the case that these workplace communications are not necessarily well written or targeted to the appropriate audience. Workplace Documents material does not include information that is presented graphically, such as in charts, forms, or blueprints.

According to the SMEs, the online, computer-based training provides audio for all the modules. The students can choose if they want to listen to the audio or prefer to read the onscreen material themselves. However, students will have to read the self-check and quizzes, instructions for skill and activity lessons; and the definition of a word if they look it up in the glossary.

Workplace Documents skills are required for 100% of the learning objectives/skills. To determine the level of Workplace Documents skill needed for the learning objectives/skills students complete, the difficulty of the reading materials and how hard it is for students to find the information they need and make use of it was considered. Dr. Hill evaluated the training material as it compares to WorkKeys Workplace Documents skill levels 3 through 6. While students will probably master Level 5 Workplace Documents skills by the completion of the course, they can enter the course with Level 4 Workplace Document skills.

At Workplace Documents Level 4, reading materials include policies, procedures, and notices. Materials are straightforward with some long sentences and contain a number of details. These materials use common words, but do have some harder words, too. They describe procedures that include several steps. When following procedures, students must think about changing conditions that affect what they should do. For example, they can follow directions that include if-then statements. When students use Level 4 skills they can identify the main idea and details that may not be clearly stated, use the reading material to figure out the meaning of words that are not defined for them (not jargon or technical terms), apply information/instructions to a situation that is the same as the situation in the reading materials, and choose what to do when changing conditions call for a different action.

Students will need to learn an enormous amount of terminology throughout the course including words associated with supply chain automation equipment, measurement, tools, power, drives, electrical circuits, voltage, inductance, capacitance, transformers, sensors, pneumatics, and hydraulics. While the words are always defined, they are not always common such as disaggregated, actuators, fulcrum, inclined planes, kinetic energy, drive sheave, viscosity, direct current, load resistance, electromagnetism, polarized, mutual inductance, dissipate, and positive displacement.

Students will need to learn some acronyms that are common in manufacturing such as National Institute of Occupational Safety and Health (NIOSH), personal protective equipment (PPE),

Hazardous Communications Standard (HCS or HazCom), and Safety Data Sheet (SDS). In addition, they will also need to learn a lot of acronyms specific to supply chain automation such as distribution center (DC), automatic storage and retrieving system(ASRS), autonomous mobile robots (AMRs), print and apply lines (Panda lines), warehouse management system (WMS), storage retrieval machine (SRM), vertical reciprocating conveyor (VRC), and motor driver roller (MDR). However, the acronyms will be explained in context. The online modules highlight terminology that students may not be familiar with by showing them in blue. These words are in the glossary. When a student clicks on the word, the full definition will appear in a pop-up box and if the student is unfamiliar with a word in the definition, they can click on that word and another pop-up box will appear with the definition for that word (Figure 30). As you can see in the example below, the word resistance is shown in blue and a definition appears in a pop-up box when the word is clicked-on.

Figure 30: Example of Glossary

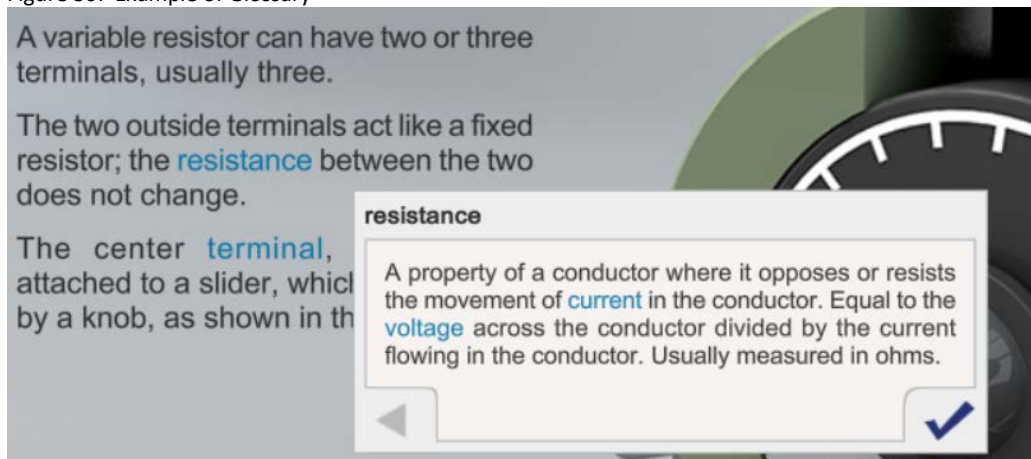

Students will need Level 4 Workplace Document skills to follow the steps of a procedure such as lock out/tag out, calibrating a dial caliper, using a grease gun to lubricate a pillow block bearing, adjusting a conveyor, replacing a flat belt on a conveyor, or maintaining a flat belt conveyor. Below is an example of step-by-step instructions a student will need to follow when replacing a spin-on filter:

Basic Steps that should be followed when removing and replacing a spin-on filter:

1. *Read installation instructions*
2. *Prepare work area*
3. *Remove old filter*
4. *Clean and inspect mounting area*
5. *Prepare new filter*
6. *Install new filter*
7. *Check installation*

While these steps are short and numbered, each step will have a follow-up screen with additional instructions for sub-steps that consist of one to four paragraphs. The sub-steps are not numbered, but use words such as before, next, first, and second to indicate the next step in the process. The instructions usually contain reminders about safety and preparation.

Step 2: Prepare work area

Before replacing a spin-on filter, first ensure that the machine is disengaged and properly locked out. Remember that hydraulic power can still be present even if electrical power is removed.

Make sure you have all of the tools you will need, including a bucket and rags to capture the spilled oil. Some spin-on filters have hand grips for easy removal, but some might require a strap wrench.

The instructions will also provide information about changing conditions that affect what the student should do. For example, “Some spin-on filters have hand grips for easy removal, but some might require a strap wrench.” The student will have to decide if they need a strap wrench. Instructions on troubleshooting may also contain conditionals. For example, the instructions for adjusting a conveyor include, “If belt tension is higher on one side, the belt will run in that direction. If this occurs, gradually adjust...”.

Instructions for the Simulator include a general introduction for the virtual trainer environment and specific step-by-step directions for each skill. The step-by-step directions for each skill include multiple sub-steps. The student must perform each step carefully to achieve the desired result. See the example in Figure 31.

Figure 31: Example of Simulator Step-by-Step Directions

11. Perform the following substeps to replace the 48-tooth idler gear with the 36-tooth gear.

The new gear train will consist of a 60-tooth drive gear, a 36-tooth idler, and a 60-tooth output gear. This will show that the size of the idler does not affect the speed ratio of the drive and output gears.

- A. Remove the 48-tooth idler gear and the 60-tooth output gear.
- B. Attach a 36-tooth gear to mounting point 1.
- C. Attach a 60-tooth gear to mounting point 4.
- D. Move the drive gear to gear motor position 3.

12. Notice the line on the drive gear and the text on the output gear.

13. Turn on the gear motor for three revolutions of the drive gear. Count and record the number of revolutions of the drive and output gears.

Drive Gear: _____ (Number of Revolutions)

Output Gear: _____ (Number of Revolutions)

The drive and output gears should have turned the same number of revolutions. The size of the idler gear does not affect the speed ratio.

While the majority of the instructions are between 3 to 10 steps with sub-steps, solving for a combination circuit involves 7 steps with 27 screens. Each screen requires the student to follow very specific directions regarding values to click on in order to continue to the next screen. For example, “Click on that value to replace R1, R2,3,4, and R5 with one resistor that represents their equivalent resistance.” If the student is not able to follow the instructions, they are not able to proceed to the next screen. Although, the cursor will turn into a pointer if it is floated over the correct location.

Instructions for troubleshooting often contain more conditional statements. For example, when troubleshooting a transformer, students will need to consider whether a transformer is already connected in a circuit or if the voltage is constant (Figure 32). Students will need Level 5 skills when working with instructions with multiple conditional statements.

Figure 32: Excerpt from Troubleshooting a Transformer Instructions

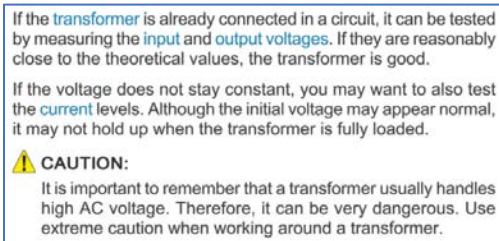

In order to understand how things work or operate, students will need to read step-by-step descriptions for a fuse, circuit, three-phase power, inductor, capacitor, voltage divider network, and a magnetic reed switch. An example of “how it works” description for a circuit breaker is provided in Figure 33.

Figure 33: How it works example for a circuit breaker

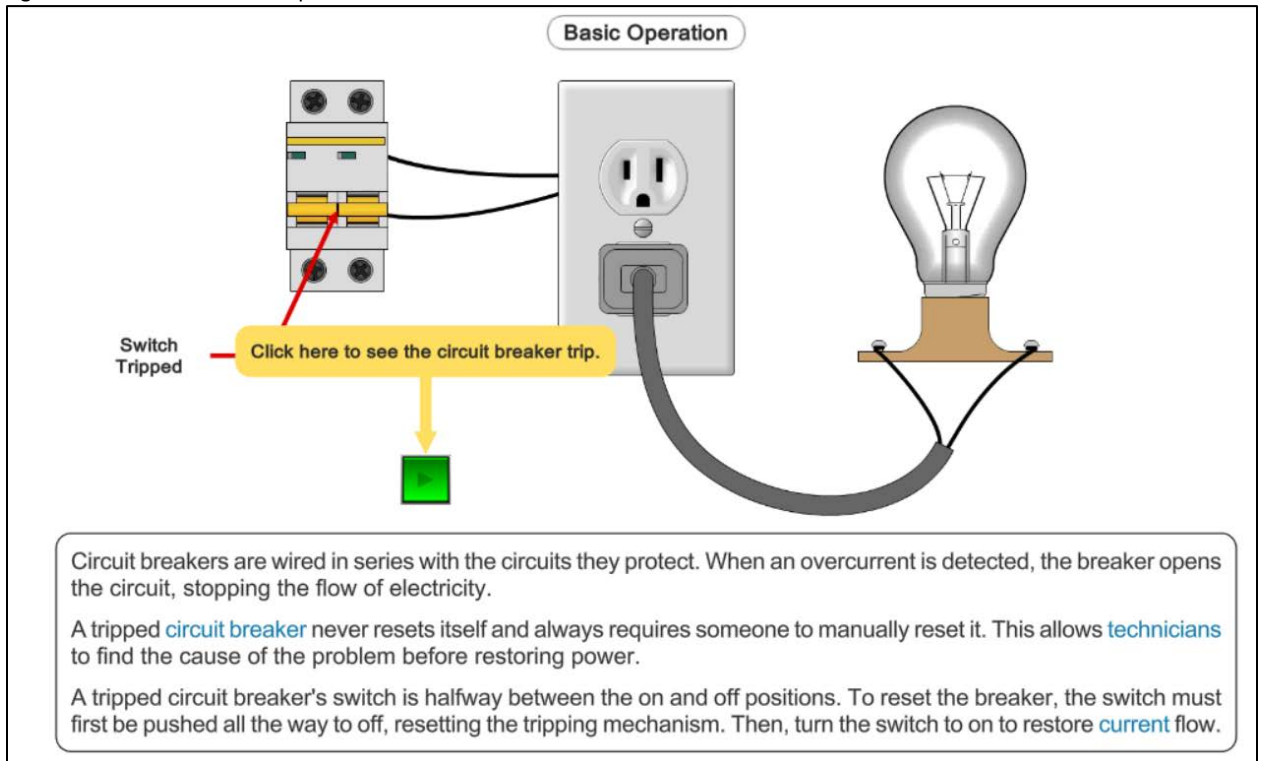

Students will be introduced to a few laws and shown how they can be applied in a system of machinery. For example, students are taught Pascal's law. The law states that when fluid is in a confined container, the same pressure exists throughout the entire volume of fluid and acts equally on all internal surfaces. Students are then shown how Pascal's law is of significance in fluid power leverage, which means that a small input force can generate a very large output force. In practice, this means that a cylinder or motor will output its full force when it first begins moving because the pressure at the actuator is at full pressure. Students are provided with an animated system demonstrating this law.

At Level 5, workplace documents include policies, procedures, announcements, legal, and multiple related documents that have many details. The information that students need is generally stated directly, but it is hard to find because there are so many details, and some may not be needed for the learning objectives/standards being performed (extraneous information). The materials include technical terms, jargon, and acronyms, or words that have several meanings. The documents may have complex sentences and/or contain conditional situations. When students use Level 5 skills on the job, in addition to using the skills described at Levels 3 and 4, they can figure out the appropriate meaning of a word based on how the word is used, and identify the appropriate meaning of technical term, jargon, or an acronym that is defined in the document. Students will also need to apply technical terms and jargon to stated situations, apply information/instructions to a new situation that is similar to the one described in the material while considering changing conditions, and apply complex

information/instructions that include conditionals to situations described in the materials. They may also need to make some inferences to accomplish their goal.

Figuring out the appropriate meaning of a word based on how the word is used and identifying the appropriate meaning of technical terms, jargon, or an acronym that are defined in the document are characteristics of Workplace Document Level 5 skills. Students also need to be able to apply technical terms and jargon to stated situations. They will learn to apply complex information/instructions that include multiple conditionals and make inferences to accomplish goals by the time they complete the training. As a result, students need Level 4 Workplace Documents skills when they enter the program and will probably have Workplace Documents Level 5 skills upon successful completion of the training.

Section 3

Results and Recommendations

The results of this project and review of its findings can be used to help guide the selection of students into the program and to encourage skill development for those applicants whose skills currently do not match the recommendations for entry. The table shows the results for entry- and exit-level performance for CT-SCA Equipment Maintenance online curriculum. Entry level is defined as the students' first day in the program, before they gain program specific knowledge from training or experience. Exit level is the point at which a student has successfully completed the training requirements. The exit levels are provided for use as training goals.

The results of this curriculum profile support the claim that the ACT NCRC helps ensure that individuals have the academic and employability skills needed to enter a demanding MSSC Certified Technician-Supply Chain Automation (CT-SCA) Equipment Maintenance certification program of training. Accelerating the use of these credentials will help individuals find jobs and provide employers with workers who have the academic, employability, and 21st century skills important to success.

The Manufacturing Skill Standards Council and ACT should continue to recognize the benefits to stakeholders of "stacking" MSSC certification credentials upon ACT's WorkKeys Assessments, specifically the National Career Readiness Certificate (NCRC) as the "foundation" for MSSC's Certified Technician-Supply Chain Automation (CT-SCA) credentialing program.

Skill Level Recommendations for Entry into and Exit from the CT-SCA Equipment Maintenance Curriculum

WorkKeys Skill	Skill Level Range	Entry	Exit
Workplace Documents	3-7	4	5
Graphic Literacy	3-7	4	5
Applied Math	3-7	4	5

APPLIED MATH SKILL

WorkKeys® Applied Math is the skill people use when they use mathematical reasoning and problem-solving techniques to solve work-related problems. Employees may use calculators and conversion tables to help with the problems, but they still need to use math skills to think them through.

There are five levels of difficulty. Level 3 is the least complex and Level 7 is the most complex. The levels build on each other, each incorporating the skills assessed at the previous levels. For example, at Level 5, employees need the skills from Levels 3, 4, and 5. Examples are included with each level description.

When deciding what level of the Applied Math skill employees need for the tasks they do at work, consider the following questions:

- How is the information presented? That is:
 - Is it presented in the same order that it is needed?
 - Is it necessary to change the order that the information is in before the math can be performed?

Is all the information needed for solving the problems provided? That is:

- Is all the information presented in the right form?
- Is it necessary to do some calculations to get some of the important information?
- Does the problem require a formula?
- Does the information need to be taken from a graphic?

What kind of mathematical operations do employees perform? That is:

- Can the math problem be completed in one step?
- Does the problem need to be done in several steps?
- Is it necessary to convert measurements from one form to another, either within or between systems of measurement?

Applied Math Level 3

Level 3 problems can easily be translated from a word problem to a math equation requiring a single type of math operation. All the needed information is presented in a logical order and there is no extra information given.

When employees use Level 3 Applied Math skills on the job, they can:

- Solve problems that require a single type of mathematical operation. They add or subtract either positive or negative numbers (such as 10 or -2). They multiply or divide using only positive numbers (such as 10).
- Convert a familiar fraction (such as $\frac{1}{2}$ or $\frac{1}{4}$ to a decimal) and convert from a decimal to a common fraction; OR convert between decimals to percentages (such as 0.75 to 75%).
- Convert between familiar units of money and time (for example, one hour equals 60 minutes or $\frac{1}{2}$ of a dollar equals \$0.50)
- Add the prices of several products to reach a total, and they can make the correct change for a customer.

Applied Math Level 4

At Level 4, tasks may present information out of order and may include extra, unnecessary information. One or two operations may be needed to solve the problem. A chart, diagram, or graph may be included.

When employees use Level 4 Applied Math skills on the job, they can use the skills described at Level 3, and they can:

- Solve problems that require one or two operations. They may add, subtract, or multiply using positive or negative numbers (such as 10, -2), and they may divide positive numbers (such as 10).
- Figure out an average or mean of a set of numbers (such as $\frac{(10+11+12)}{3}$). For this they use whole numbers and decimals.
- Figure out simple ratios (such as $\frac{3}{4}$), simple proportions (such as $\frac{10}{100}$ cases), or rates (such as 10 mph).
- Add commonly known fractions, decimals, or percentages (such as $\frac{1}{2}$, .75, or 25%).
- Add or subtract fractions that share a common denominator (such as $\frac{1}{8} + \frac{3}{8} + \frac{7}{8}$).
- Multiply a mixed number (such as $12\frac{1}{8}$) by a whole number or decimal.
- Put the information in the right order before they perform calculations.

For example, at this level, employees can figure out sales tax or a sales commission on a previously calculated total, and they can find out rates of use or business flow.

Applied Math Level 5

In Level 5 problems, the information may not be presented in logical order; the item may contain extraneous information; it may contain a chart, graph or diagram; and the mathematical set-up may be complicated. In solving, the test taker may need to perform multiple operations. For example, at this level employees may complete an order form by totaling an order and then computing tax.

When employees use Level 5 Applied Math skills on the job, they can use the skills described at Levels 3 and 4, and they can:

- Decide what information, calculations, or unit conversions to use to find the answer to a problem.
- As part of a multiple step problem, the employee may have to find one value and use it to find another value that answers the question.
- Add and subtract fractions with unlike denominators (such as $\frac{1}{2} - \frac{1}{4}$).
- Convert units within or between systems of measurement (e.g., time, measurement, and quantity) where the formula is provided such as converting from ounces to pounds or from centimeters to inches.
- Solve problems that require mathematical operations Calculate using mixed units, such as adding 3.50 hours and 4 hours 30 minutes or subtracting 3 feet and 10 inches from 6 feet and 4 inches.
- Identify the best deal by doing one- and two-step calculations and then comparing the results to determine the solution that meets the stated conditions.
- Calculate perimeters, circumference, and areas of basic shapes like rectangles and circles.
- Calculate a given percentage of a given number and then use that percentage to determine the solution (e.g., find the total cost of a product after calculating discount, markup or tax).
- Identify where a mistake occurred in a calculation (such as identifying the row in a spreadsheet where a problem occurred).

Applied Math Level 6

Level 6 tasks may require considerable translation from verbal form to mathematical expression. They generally require considerable setup and involve multiple-step calculations.

When employees use Level 6 Applied Math skills on the job, they can use the skills described at Levels 3, 4, and 5, and they can:

- Use fractions with unlike denominators and calculate reverse percentages.
- Convert units within or between systems of measurement (e.g., time, measurement, and quantity) where multiple-step conversions are required and the formulas are provided such as converting from kilometers to meters to feet.
- Identify why a mistake occurred in a solution.
- Find the best deal and use the result for another calculation.
- Find the area of basic shapes (rectangles and circles) when it may be necessary to rearrange the formula, convert units of measurement in the calculations, or use the result in further calculations.
- Find the volume of rectangular solids.
- Calculate rates, productions rates, rate by time (such as, production rate is 59 cups produced per hour, how many will be produced in an 8 hour shift).
- Identify the correct equation for solving a problem

Applied Math Level 7

At Level 7, the task may be presented in an unusual format and the information presented may be incomplete or require the employee to make an assumption. Tasks often involve multiple steps of logic and calculation, and multiple operations.

When employees use Level 7 Applied Math skills on the job, they can use the skills described at Levels 3, 4, 5, and 6, and they can:

- Solve problems that include ratios, rates, or proportions with at least one of the quantities related to a fraction
- Identify the reason for a mistake.
- Convert between units of measurement that involve fractions, mixed numbers, decimals, or percentages.
- Find the area of multiple shapes or find the area of a composite shape.
- Calculate volumes of spheres, cylinders, or cones
- Calculate the volume when it may be necessary to rearrange the formula, convert units of measurement in the calculations, or use the result in further calculations
- Set up and manipulate ratios, rates or proportions where at least one of the quantities is a fraction.
- Determine the better economic value of several alternatives by using graphics or by finding a percentage difference or a unit cost.
- Apply basic statistical concepts for example calculate the weighted mean, interpret measures of central tendency, or interpret measure of spread and tolerance.

GRAPHIC LITERACY SKILL

The WorkKeys Graphic Literacy skill is the skill people use when they work with workplace graphics such as tables, graphs, charts, digital dashboards, flow charts, timelines, forms, maps, and blueprints. Employees use this skill when they find, summarize, compare, and analyze information to make decisions using workplace graphics to solve work-related problems.

Graphic Literacy Level 3

At Level 3, workplace graphics are common and of simple or low moderate difficulty.

Characteristics of simple graphics include:

- A limited amount of data (i.e., less than twenty data points/fields)
- One level of data such as number of items in inventory
- One or two variables such as day of the week and number of items in inventory
- If there are axes, there will be one or two, such as an x and/or y axis

Characteristics of low moderate graphics include:

- A moderate amount of data
- More than one level of data, but no nesting
- Several variables
- If there are axes, there will be one or two
- If two simple graphics are required to solve the problem, they should be considered a low moderate graphic.

At Level 3, employees use one simple or low moderate graphic at a time to perform the following tasks:

- Locate and find information
- Identify the next or missing step in a process

Graphic Literacy Level 4

At Level 4, workplace graphics are common and of low to high moderate difficulty.

Characteristics of low moderate graphics include:

- A moderate amount of data
- More than one level of data, but no nesting
- Several variables
- If there are axes, there will be one or two
- If two simple graphics are required to solve the problem, they should be considered a low moderate graphic.

At Level 4, employees have demonstrated all of the skills defined at Level 3 and they can use one or two low moderate graphics at a time to perform the following tasks:

- Locate information in a graphic using information found in another graphic
- Compare two or more pieces of information
- Identify a trend/pattern/relationship
- Make an inference or decision
- Identify the graphic that accurately represents the data

High moderate graphics may be less common and have the following characteristics:

- A moderate amount of data
- More than one level of data and it may be nested
- Many variables such as types of wood, drill speeds, hole diameter, and type of bit
- If there are axes, there will be one or two such as an x and/or y axis.
- If a low moderate graphic and a simple graphic are required to solve the problem, they should be considered a high moderate graphic.

At Level 4, employees have demonstrated all of the skills defined at Level 3 and they can use one high moderate graphic to perform the following tasks:

- Locate and find information
- Identify the next or missing step in a process

Graphic Literacy Level 5

At Level 5, workplace graphics may be less common and of low moderate, high moderate, or difficult complexity.

Characteristics of low moderate graphics include:

- A moderate amount of data
- More than one level of data, but no nesting
- Several variables
- If there are axes, there will be one or two.
- If two simple graphics are required to solve the problem, they should be considered a low moderate graphic.

At level 5, employees have demonstrated all of the skills defined at Levels 3 and 4, and they can use a low moderate graphic to perform the following tasks:

- Compare two or more pieces of information
- Interpret a trend/pattern/relationship
- Make a reasonable inference or decision based on one graphic after finding information in another graphic
- Justify a decision or inference based on information
- Identify the most effective graphic for the task
- Justify the most effective graphic for the task

High moderate graphics may be less common and have the following characteristics:

- A moderate amount of data
- More than one level of data and it may be nested
- Many variables
- If there are axes, there will be one or two.
- If a low moderate graphic and a simple graphic are required to solve the problem, they should be considered a high moderate graphic.

Graphic Literacy Level 5 Continued

At Level 5, employees have demonstrated all of the skills defined at Level 3 and 4, and they can use one high moderate graphic to perform the following tasks:

- Locate information in a graphic using information found in another graphic
- Compare two or more pieces of information
- Identify a trend/pattern/relationship
- Make an inference or decision
- Identify the graphic that accurately represents the data

Difficult graphics are likely to be less common or a composite of graphics and have the following characteristics:

- Data presented is dense.
- More than one level of data and nesting is likely
- Many variables such as types of wood, drill speeds, hole diameter, and type of bit
- If there are axes, there will be three or more such as an x, y, and z axis.
- If a high moderate graphic and a low moderate graphic are required to solve the problem, they should be considered a difficult graphic.

At Level 5, employees have demonstrated all of the skills defined at Level 3 and 4, and they can use one difficult graphic to perform the following tasks:

- Locate and find information
- Identify the next or missing step in a process

Graphic Literacy Level 6

At Level 6, workplace graphics may be less common and of high moderate or difficult complexity.

High moderate graphics may be less common and have the following characteristics:

- A moderate amount of data
- More than one level of data and it may be nested
- Many variables
- If there are axes, there will be one or two
- If a low moderate graphic and a simple graphic are required to solve the problem, they should be considered a high moderate graphic.

At level 6, employees have demonstrated all of the skills defined at Levels 3, 4 and 5, and they can use a high moderate graphic to perform the following tasks:

- Compare two or more pieces of information
- Interpret a trend/pattern/relationship
- Make a reasonable inference or decision based on one graphic after finding information in another graphic
- Justify a decision or inference based on information
- Identify the most effective graphic for the task
- Justify the most effective graphic for the task

Difficult graphics are likely to be less common or a composite of graphics and have the following characteristics:

- Data presented is dense.
- More than one level of data and nesting is likely
- Many variables
- If there are axes, there will be three or more.
- If a low moderate graphic and a high moderate graphic are required to solve the problem, they should be considered a difficult graphic.

Graphic Literacy Level 6 Continued

At Level 6, employees have demonstrated all of the skills defined at Level 3, 4 and 5, and they can use one difficult graphic to perform the following tasks:

- Locate information in a graphic using information found in another graphic
- Compare two or more pieces of information
- Identify a trend/pattern/relationship
- Make an inference or decision
- Identify the graphic that accurately represents the data

Graphic Literacy Level 7

At Level 7, workplace graphics may be less common and of difficult complexity.

Difficult graphics are likely to be less common or a composite of graphics and have the following characteristics:

- Data presented is dense.
- More than one level of data and nesting is likely
- Many variables
- If there are axes, there will be three or more.
- If a low moderate graphic and a high moderate graphic are required to solve the problem, they should be considered a difficult graphic.

At level 7, employees have demonstrated all of the skills defined at Levels 3, 4, 5 and 6, and they can use a difficult graphic to perform the following tasks:

- Compare two or more trends/patterns/relationships
- Interpret a trend/pattern/relationship
- Make a reasonable inference or decision based on one graphic after finding information in another graphic
- Justify an inference or decision based on information
- Identify the most effective graphic for the task
- Justify the most effective graphic for the task

WORKPLACE DOCUMENTS

Employees read and use workplace documents in order to do a job. The documents include, but are not limited to, messages, emails, letters, directions, signs, notices, bulletins, policies, websites, contracts, and regulations and are based on materials that reflect the actual reading demands of the workplace.

It is often the case that these workplace communications are not necessarily clearly written or targeted to the appropriate audience. These documents do not include information that is presented graphically, such as in charts, forms, or blueprints.

There are five levels of difficulty. Level 3 is the least complex and Level 7 is the most complex. The levels build on each other, each incorporating the skills assessed at the preceding levels. For example, at Level 5, employees need the skills from Levels 3, 4, and 5. The reading materials at Level 3 are short and direct. The material becomes longer, denser, and more difficult to use as readers move toward Level 7. The tasks also become more complex as readers move from Level 3 to Level 7. At Level 3, readers begin by finding very obvious details and following short instructions. At the more complex levels, tasks can also involve more application and interpretation.

When you consider what level of skill is needed for the tasks employees complete on the job, you might consider the following questions:

How difficult are the materials? For example:

- Are the sentences short, simple, and clear; or are they complex and possibly even confusing?
- Do the materials use only common words; or do they include difficult words, jargon, and words used in unfamiliar ways?
- How much extra information is included?

How complicated is the task? For example:

- Is it only necessary to use information that is stated clearly?
- Is it necessary to make inferences based on the reading materials before using the information?
- Do the employees need to apply the information to a situation exactly like the one described in the materials or to one that is quite different?

Workplace Documents Level 3

Level 3 reading materials include basic work related policies, procedures, and announcements with the following characteristics:

- They are short, with no extra information.
- Employees read the materials to find out what they should do.
- All the information within the document is stated clearly and directly.
- Short sentences and common, everyday, and workplace words (such as employee, timecard, office) are used.
- The document contains a small number of clearly stated details.

When employees use Level 3 skills on the job, they can:

- Find the main ideas and clearly stated details.
- Choose when to perform each step in a series of short steps.
- Apply information/instructions to a situation that is the same as the one they are reading about (such as knowing what button to push first after reading instructions on how to run a copy machine).

Workplace Documents Level 4

Level 4 workplace documents include policies, procedures, and notices with the following characteristics:

- They are straightforward with some long sentences and contain a number of details.
- These materials use common words, but do have some harder words, too.
- They describe procedures that include several steps.
- When following the procedures, employees must think about changing conditions that affect what they should do. For example, they can follow directions that include “if-then” statements.

When employees use Level 4 skills on the job, in addition to using Level 3 skills, they can:

- Identify the main idea and details that may not be clearly stated.
- Use the reading material to figure out the meaning of words that are not defined for them (not jargon or technical terms).
- Apply information/instructions to a situation that is the same as the situation in the reading materials.
- Choose what to do when changing conditions call for a different action.

Workplace Documents Level 5

At Level 5, workplace documents include policies, procedures, announcements, legal, and multiple related documents that have many details with the following characteristics:

- The information that employees need is generally stated directly, but it is hard to find because there are so many details and some may not be needed for the task being performed (extraneous information).
- The materials include technical terms, jargon, and acronyms, or words that have several meanings.
- The documents may have complex sentences and/or contain conditional situations.

When employees use Level 5 skills on the job, in addition to using the skills described at Levels 3 and 4, they can:

- Figure out the appropriate meaning of a word based on how the word is used.
- Identify the appropriate meaning of technical term, jargon, or an acronym that is defined in the document.
- Apply technical terms and jargon to stated situations.
- Apply information/instructions to a new situation that is similar to the one described in the material while considering changing conditions.
- Apply complex information/instructions that include conditionals to situations described in the materials.
- They may need to make some inferences to accomplish their goal.

Workplace Documents Level 6

At Level 6, workplace documents include policies, informational, instructional (procedures), legal, and multiple related documents with the following characteristics:

- They use mostly complicated sentences.
- Documents may be long and/or complex and/or contain conditional situations.
- There are implied and/or extraneous details with difficult words, jargon, and technical terms.
- Most of the information is not clearly stated.
- Meanings may need to be determined from context.

When employees use Level 6 skills on the job, in addition to using the skills at Levels 3, 4, and 5, they can:

- Infer implied details.
- Infer the meaning of an acronym, jargon, or technical term from context.
- Apply information/instructions to a situation not directly described or to a completely new situation.
- Apply principles inferred in a passage to a situation not directly described or to a completely new situation.
- Identify the rationale behind a procedure, policy, or communication.

Workplace Documents Level 7

At Level 7, workplace documents include policies, informational, instructional (procedures), legal, and multiple related documents with the following characteristics:

- The documents contain a lot of details, and the concepts are complicated.
- May cover uncommon topics (concepts) and/or contain conditional situations.
- There are implied and extraneous details.
- Advanced, unfamiliar, and/or uncommon words, technical terms, and jargon; meanings must be determined from context.
- Not clearly stated, pieces of information may be spread throughout the document and may be extraneous.

When employees use Level 7 skills on the job, in addition to using the skills at Levels 3, 4, 5, and 6, they can:

- Infer the meaning of an acronym, jargon or technical term from context.
- Apply principles inferred from the materials to a situation not directly described or to a completely new situation.
- Identify the rationale behind an entire document or a section of a document.
- Infer implied details.

Appendix B

Learning Objectives

The learning objectives, skills and activities for the program are shown in the table below. An “X” in a skill column means that the objective/skill/activity on that row requires that skill.

Objective/Skill/Activity		Applied Math	Graphic Literacy	Workplace Documents
Introduction to Supply Chain Automation				
OBJ 1	Describe Applications of Supply Chain Automation			X
OBJ 2	Describe Types of Distribution Center Containers		X	X
OBJ 3	Describe Types of Distribution Center Automation			X
OBJ 4	Describe Supply Chain Automation Control Systems		X	X
OBJ 5	Describe Types of Sortation Systems		X	X
OBJ 6	Describe Types of Automated Storage and Retrieval Systems			X
OBJ 7	Describe Types of Picking Systems		X	X
OBJ 8	Describe Types of Packaging, Weighing and Labeling Systems			X
Practicing Safety in the Workplace				
OBJ 1	Explain How to Create a Culture of Safety in the Workplace		X	X
OBJ 2	Define an Injury and Identify Common Types		X	X
OBJ 3	Define an Accident and Identify Common Types		X	X
OBJ 4	Define Personal Protective Equipment		X	X
OBJ 5	Identify Seven Types of Personal Protective Equipment		X	X
OBJ 6	Describe an Employer's PPE Responsibilities			X
OBJ 7	Describe How to Identify Hazards in the Workplace			X
OBJ 8	Describe 11 Types of Hazards Found in the Workplace		X	X
Types of PPE				
OBJ 1	Describe the Types of Head PPE			X
OBJ 2	Describe the Types of Eye PPE		X	X
OBJ 3	Describe the Types of Ear PPE		X	X
OBJ 4	Describe the Types of Hand and Arm PPE			X
OBJ 5	Describe the Types of Foot PPE		X	X
OBJ 6	Describe the Types of Respiratory PPE			X
OBJ 7	Describe the Types of Body PPE		X	X
Machine Safety				
OBJ 1	Describe Clothing Safety Guidelines for Machine Operators			X

Objective/Skill/Activity		Applied Math	Graphic Literacy	Workplace Documents
OBJ 2	Describe the Machine Operation Safety Guidelines			X
OBJ 3	Describe the Types of Machine Guards			X
OBJ 4	Describe the Operation of Machine Interlocks			X
OBJ 5	Describe the Operation of Emergency Stop Controls		X	X
OBJ 6	Describe the Function of a Lockout/Tagout System			X
OBJ 7	Describe How to Perform an Electrical Lockout/Tagout		X	X
Operating Supply Chain Automation				
OBJ 1	Describe the Basic Operation of an Automated Machine		X	X
OBJ 2	Describe the Basic Operation of a Line-Type Sortation System		X	X
OBJ 3	Describe How to Use a Human Machine Interface (HMI) with Warehouse Control Software		X	X
OBJ 4	Describe the Basic Steps to Operate a Sortation System		X	X
OBJ 5	Describe Types of Distribution Center Metrics		X	X
OBJ 6	Describe How to Recognize and Correct Automated System Malfunctions		X	X
Dimensional Measurement				
OBJ 1	Define Dimensional Measurement and Explain Its Importance		X	X
OBJ 2	Describe Two Systems of Dimensional Measurement Used in Manufacturing: US Customary and SI		X	X
OBJ 3	Describe How to Use an SI Machinist Rule		X	X
OBJ 4	Define Measurement Accuracy and Precision		X	X
OBJ 5	Define Resolution and Explain Its Effect on Accuracy		X	X
Skill 1	Use a Metric Rule to Measure an Outside Length of a Part		X	X
OBJ 6	Describe How to Use a US Customary Machinist Rule	X	X	X
Skill 2	Use a US Customary Machinist Rule to Measure a Length	X	X	X
Caliper Measurement				
OBJ 1	Describe the Function of a Precision Measurement Tool		X	X
OBJ 2	Describe the Basic Operation of a Dial Caliper		X	X
OBJ 3	Describe How to Calibrate a Dial Caliper		X	X
OBJ 4	Describe How to Use a Dial Caliper	X	X	X
OBJ 5	State the Typical Accuracy of a Dial Caliper Measurement and Explain What Affects It		X	X
Skill 1	Perform Measurements Using a Dial Caliper	X	X	X
OBJ 6	Describe the Basic Operation of a Digital Caliper		X	X
OBJ 7	Describe How to Use a Digital Caliper		X	X
Skill 2	Perform Measurements Using a Digital Caliper		X	X

Objective/Skill/Activity		Applied Math	Graphic Literacy	Workplace Documents
Micrometer Measurement				
OBJ 1	Describe the Basic Operation of a Micrometer		X	X
OBJ 2	Describe How to Read a Micrometer with SI Units		X	X
OBJ 3	Describe How to Test Micrometer Calibration		X	X
OBJ 4	Describe How to Use an Outside Micrometer with SI Units		X	X
Skill 1	Perform Measurements Using an Outside Micrometer	X	X	X
OBJ 5	Describe How to Use an Inside Micrometer	X	X	X
OBJ 6	Explain a Micrometer's Accuracy		X	X
Equipment and Workplace Safety				
OBJ 1	Describe Types of Hand Tools and Power Tools		X	X
OBJ 2	Describe the Hand Tool Safety Guidelines			X
OBJ 3	Describe the Portable Power Tool Safety Guidelines			X
OBJ 4	Describe Platform and Ladder Safety Guidelines			X
OBJ 5	Describe Walkway Safety Guidelines			X
OBJ 6	Describe Hazardous Material Handling Guidelines			X
OBJ 7	Describe Housekeeping Safety Guidelines			X
Hand Tools 1				
OBJ 1	Describe Basic Types of Fasteners		X	X
OBJ 2	Describe How Parts Are Assembled Using Threaded Fasteners		X	X
OBJ 3	Describe How to Use a Combination Wrench		X	X
OBJ 4	Describe How to Use a Socket Wrench		X	X
OBJ 5	Describe How to Use a Backup Wrench		X	X
OBJ 6	Describe How to Use a Hex Key Wrench		X	X
OBJ 7	Describe How to Use a Straight-Slotted Screwdriver		X	X
OBJ 8	Describe How to Use a Phillips Head Screwdriver		X	X
Mechanical Power				
OBJ 1	Define Force and Give Its Units of Measurement		X	X
OBJ 2	Define Weight and Give Its Units of Measurement		X	X
OBJ 3	Define Mass and Give Its Units of Measurement	X	X	X
OBJ 4	Define Work and Give Its Units of Measurement	X	X	X
OBJ 5	Define Mechanical Power and Give Its Units of Measurement	X	X	X
OBJ 6	Describe Two Types of Stored Mechanical Energy		X	X
OBJ 7	Describe Hooke's Law and Explain Its Importance	X	X	X
Skill 1	Use a Spring Scale to Measure Forces and Weights		X	X
Basic Mechanical Elements				

Objective/Skill/Activity		Applied Math	Graphic Literacy	Workplace Documents
OBJ 1	Describe Three Types of Basic Mechanisms		X	X
OBJ 2	Describe Three Types of Levers		X	X
Skill 1	Operate a First-Class Lever		X	X
OBJ 3	Define Torque and Give Its Units of Measurement	X	X	X
OBJ 4	Define Mechanical Advantage	X	X	X
Skill 2 -	Measure the Mechanical Advantage of a First-Class Lever		X	X
OBJ 5	Define Rotary Mechanical Power	X	X	X
Power Efficiency				
OBJ 1	Define Friction and Explain Its Importance		X	X
OBJ 2	Define Static and Kinetic Friction		X	X
OBJ 3	Define Rolling Resistance		X	X
OBJ 4	Describe the Effect of Friction on Machine Operation			X
Skill 1	Measure the Force Required to Overcome Friction in Different Applications		X	X
OBJ 5	Define Power Efficiency	X	X	X
Mechanical Power Transmission				
OBJ 1	Describe the Function of a Mechanical Power Transmission System		X	X
OBJ 2	Describe Methods of Coupling a Mechanical Power Transmission		X	X
OBJ 3	Describe Methods of Parallel Shaft Mechanical Power Transmission		X	X
OBJ 4	Describe the Basic Operation of a Bearing		X	X
OBJ 5	Describe How to Install and Adjust a Pillow Block Bearing		X	X
OBJ 6	Describe Two Methods of Mounting a Shaft Bearing and Give an Application of Each		X	X
OBJ 7	Describe the Basic Operation of a Shaft Coupling		X	X
Gear Drives				
OBJ 1	Describe the Basic Operation of a Gear Drive		X	X
OBJ 2	Describe How to Calculate Gear Ratio	X	X	X
OBJ 3	Describe How to Calculate Gear Drive Speed	X	X	X
OBJ 4	Describe How to Calculate Gear Drive Torque	X	X	X
OBJ 5	Describe How to Install a Gearbox		X	X
Skill 1	Measure the Mechanical Advantage of a Gear Drive	X	X	X
Chain Drives				
OBJ 1	Describe the Basic Operation of a Chain Drive		X	X
OBJ 2	Describe How to Calculate Sprocket Ratio	X	X	X
OBJ 3	Describe How to Calculate Chain Drive Speed	X	X	X

Objective/Skill/Activity		Applied Math	Graphic Literacy	Workplace Documents
OBJ 4	Describe How to Calculate Chain Drive Torque	X	X	X
OBJ 5	Describe How to Align a Chain Drive		X	X
OBJ 6	Describe How to Adjust Chain Drive Sag	X	X	X
Belt Drives				
OBJ 1	Describe the Basic Operation of a Belt Drive		X	X
OBJ 2	Describe How to Calculate Belt Drive Ratio	X	X	X
OBJ 3	Describe How to Calculate Belt Drive Speed	X	X	X
OBJ 4	Describe How to Calculate Belt Drive Torque	X	X	X
Skill 1	Measure the Mechanical Advantage of a Pulley Combination	X	X	X
OBJ 5	Describe How to Align a Belt Drive		X	X
OBJ 6	Describe How to Tension a Belt Drive		X	X
Oil Lubrication				
OBJ 1	Describe Types of Lubricants and Give an Application of Each			X
OBJ 2	Describe Types of Lubricant Additives			X
OBJ 3	Describe Three Types of Oils and Give an Application of Each			X
OBJ 4	Describe How Oils Are Specified		X	X
Skill 1	Select an Oil Specification for a Given Application		X	X
OBJ 5	Describe How to Obtain and Analyze an Oil Sample			X
OBJ 6	Describe the Types of Lubrication Application Methods			X
Grease Lubrication				
OBJ 1	Describe Types of Greases			X
OBJ 2	Describe How Greases Are Specified		X	X
OBJ 3	Describe the Operation of a Grease Gun		X	X
OBJ 4	Explain How to Use a Grease Gun to Lubricate a Pillow Block Bearing			X
Skill 1	Use a Grease Gun to Lubricate a Pillow Block Bearing		X	X
Conveyors				
OBJ 1	Describe Types of Conveyors and Give an Application		X	X
OBJ 2	Describe the Operation of a Flat Belt Conveyor		X	X
OBJ 3	Describe Types of Roller Conveyors and Give an Application			X
OBJ 4	Describe Conveyor Safety Guidelines		X	X
OBJ 5	Describe How to Adjust a Flat Belt Conveyor		X	X
OBJ 6	Describe How to Replace a Conveyor Belt		X	X
OBJ 7	Describe How to Maintain a Flat Belt Conveyor			X
Basic Electrical Circuits				

Objective/Skill/Activity		Applied Math	Graphic Literacy	Workplace Documents
OBJ 1	Define Electricity and Give an Application			X
OBJ 2	Describe the Operation of a Basic Electrical Circuit		X	X
OBJ 3	Describe the Two Types of Electrical Current and Give an Application of Each		X	X
OBJ 4	Describe the Operation of Two Types of Power Supplies		X	X
OBJ 5	Describe How to Interpret a Basic Electrical Schematic		X	X
Skill 1	Connect and Operate a Power Supply		X	X
OBJ 6	Describe the Functions of Three Types of Manual Switches			X
OBJ 7	Describe the Basic Operation of a Pushbutton Switch		X	X
OBJ 8	Describe the Basic Operation of a Selector Switch			X
OBJ 9	Describe the Basic Operation of a Knife Switch		X	X
Skill 2	Connect and Operate a Circuit Using Three Types of Manual Switches		X	X
OBJ 10	Describe the Function of Five Types of Electrical Output Devices and Give an Application of Each		X	X
Skill 3	Connect and Operate Four Types of Electrical Output Devices		X	X
Electrical Voltage and Current Concepts				
OBJ 1	Define Voltage and Give Its Units of Measurement			X
OBJ 2	Define Current and Give Its Units of Measurement			X
OBJ 3	State Kirchhoff's Circuit Laws and Give an Application	X	X	X
OBJ 4	Define the Basic Characteristics of Series and Parallel Circuits	X	X	X
Voltage and Current Measurement				
OBJ 1	Describe the Function of a Voltmeter and Give Its Schematic Symbol		X	X
OBJ 2	Describe How to Use a Voltmeter to Measure Voltage		X	X
Skill 1	Use an Analog Voltmeter to Measure the Voltage Drops and Point Voltages		X	X
OBJ 3	Describe How to Use a Digital Multimeter to Measure Voltage		X	X
Skill 2	Use a DMM to Measure Voltages in Series and Parallel Circuits	X	X	X
OBJ 4	Describe Two Types of Ammeters and Give Their Schematic Symbol			X
OBJ 5	Describe How to Use a DMM to Measure Current		X	X
Skill 3	Use a DMM to Measure Current in Series and Parallel Circuits		X	X
Electrical Resistance Measurement				
OBJ 1	Define Resistance and Give Its Units of Measurement		X	X

Objective/Skill/Activity		Applied Math	Graphic Literacy	Workplace Documents
OBJ 2	Describe Two Types of Ohmmeters and Give Their Schematic Symbol		X	X
OBJ 3	Describe How to Use a DMM to Measure Resistance		X	X
Skill 1	Use a DMM to Measure Resistance		X	X
OBJ 4	Describe the Resistance Characteristics in Series and Parallel Circuits	X	X	X
Skill 2	Measure the Resistance in Series and Parallel Circuits	X	X	X
OBJ 5	State Ohm's Law and Give an Application	X	X	X
Skill 3	Use Ohm's Law to Analyze a Circuit	X	X	X
OBJ 6	Define Continuity and Explain Its Importance		X	X
OBJ 7	Describe How to Use a DMM to Measure Continuity		X	X
Skill 4	Test the Continuity of Wires Using a DMM		X	X
Power in Electrical Circuits				
OBJ 1	Define Electrical Power and Give Its Units of Measurement			X
OBJ 2	Describe How to Calculate the Power in a Simple Circuit	X	X	X
OBJ 3	Describe the Function of Three Types of Circuit Protection and Give an Application of Each			X
OBJ 4	Describe the Operation of a Fuse and Give Its Schematic Symbol		X	X
Skill 1	Connect and Operate a Circuit that Uses a Fuse		X	X
OBJ 5	Describe the Basic Operation of a Circuit Breaker and Give Its Schematic Symbols		X	X
Skill 2	Connect and Operate a Circuit That Uses a Circuit Breaker		X	X
OBJ 6	Describe How to Size Circuit Protection		X	X
OBJ 7	Describe the Basic Operation of Three-Phase Power		X	X
Inductance				
OBJ 1	Define Electromagnetism and Give an Application		X	X
ACTV 1	Test an Electromagnetic Field		X	X
OBJ 2	Describe the Function of Four Electromagnetic Devices		X	X
ACTV 2	Electromagnetic Device Operation		X	X
Skill 1	Connect and Operate a Relay in a Circuit		X	X
OBJ 3	Define Inductance and Give Its Unit of Measurement		X	X
OBJ 4	Describe the Operation of an Inductor and Give Its Schematic Symbol		X	X
OBJ 5	Describe the Effect of an Inductor in a DC Circuit and Give an Application	X	X	X
ACTV 3	Effect of Inductance in a DC Circuit	X	X	X
OBJ 6	Describe the Effect of an Inductor in an AC Circuit and Give an Application	X	X	X

Objective/Skill/Activity		Applied Math	Graphic Literacy	Workplace Documents
ACTV 4	Effect of Inductive Reactance in an AC Circuit	X	X	X
Capacitance				
OBJ 1	Define Capacitance and Give Its Units of Measurement			X
OBJ 2	Describe the Operation of a Capacitor and Give Its Schematic Symbol		X	X
OBJ 3	Describe the Functions of Three Types of Capacitors	X	X	X
Skill 1	Discharge a Capacitor		X	X
Skill 2	Test a Capacitor with a DMM		X	X
OBJ 4	Describe the Effect of a Capacitor in a DC Circuit and Give an Application		X	X
Skill 3	Measure the Voltage Across a Charged Capacitor		X	X
ACTV 1	Effect of a Capacitor in a DC Circuit		X	X
OBJ 5	Describe the Effect of a Capacitor in an AC Circuit and Give an Application	X	X	X
ACTV 2	Effect of a Capacitor in an AC Circuit	X	X	X
Combination Circuits				
OBJ 1	Define a Series-Parallel Circuit		X	X
OBJ 2	Describe a Method for Identifying the Series and Parallel Sections of a Circuit		X	X
Skill 1	Trace the Current Path in a Combination Circuit		X	X
OBJ 3	List the Seven Steps for Solving a Combination Circuit	X	X	X
Skill 2	Solve a Combination Circuit	X	X	X
OBJ 4	Describe How Switches Are Used in Combination Circuits and Give an Application		X	X
Skill 3	Connect and Operate a Basic Lighting Circuit		X	X
Skill 4	Connect and Operate a Ceiling Fan Circuit		X	X
OBJ 5	Describe the Function of a Variable Resistor and Give an Application			X
ACTV 1	Rheostat Operation	X	X	X
Skill 5	Connect and Operate a Rheostat as a Light Dimmer		X	X
Voltage Dividers				
OBJ 1	Describe the Function of a Voltage Divider and Give an Application		X	X
OBJ 2	Describe the Operation of Three Types of Voltage Dividers	X	X	X
Skill 1	Design a Voltage Divider Network	X	X	X
Skill 2	Connect and Operate a Voltage Divider Network		X	X
OBJ 3	Explain the Effect of a Short Circuit		X	X
OBJ 4	Describe the Four Steps for Troubleshooting a Short Circuit		X	X
Skill 3	Locate a Short Circuit		X	X

Objective/Skill/Activity		Applied Math	Graphic Literacy	Workplace Documents
OBJ 5	Describe the Three Basic Steps for Troubleshooting an Open Circuit		X	X
Skill 4	Locate an Open Circuit		X	X
Transformers				
OBJ 1	Describe the Function of a Transformer and Give an Application			X
OBJ 2	Describe the Operation of a Transformer and Give Its Schematic Symbol		X	X
Skill 1	Connect and Operate a Transformer		X	X
OBJ 3	Describe How to Calculate the Output Voltage of a Transformer	X		X
Skill 2	Calculate the Secondary Coil Voltage of a Transformer	X	X	X
OBJ 4	Describe How to Troubleshoot a Transformer			X
Skill 3	Troubleshoot a Transformer by Measuring Continuity		X	X
OBJ 5	Describe How to Size a Transformer	X	X	X
Skill 4	Size a Transformer	X	X	X
OBJ 6	Describe a Transformer's Input and Output Power Relationship and Explain Its Importance	X	X	X
Introduction to Electronic Sensors				
OBJ 1	List Five Advantages of Electronic Sensors and Two Disadvantages			X
OBJ 2	List Five Types of Electronic Sensors		X	X
OBJ 3	Describe the Function of the Two Parts of an Electronic Sensor		X	X
OBJ 4	Describe the Operation of Two Types of Transistors Used in Electronic Sensors		X	X
OBJ 5	Describe the Operation of an Inductive Proximity Sensor and Give an Application		X	X
OBJ 6	Describe Five Characteristics That Affect Inductive Proximity Sensor Operation		X	X
OBJ 7	Describe the Operation of a Capacitive Proximity Sensor and Give an Application		X	X
OBJ 8	Describe Five Characteristics That Affect Capacitive Proximity Sensor Operation		X	X
Electronic Sensors 2				
OBJ 1	Describe the Operation of a Magnetic Reed Switch and Give an Application		X	X
OBJ 2	Describe Six Characteristics That Affect Magnetic Reed Switch Operation		X	X
OBJ 3	Describe the Operation of a Photoelectric Sensor and Give an Application		X	X

Objective/Skill/Activity		Applied Math	Graphic Literacy	Workplace Documents
OBJ 4	Describe Five Characteristics That Affect Photoelectric Sensor Operation		X	X
OBJ 5	Explain How to Interface Electronic Sensors with Machine Controllers		X	X
Introduction to Fluid Power				
OBJ 1	Define Fluid Power and Give an Application		X	X
OBJ 2	Describe the Basic Components of a Hydraulic System		X	X
OBJ 3	Describe the Basic Components of a Pneumatic System		X	X
OBJ 4	Describe the Advantages of Hydraulic and Pneumatic Systems		X	X
OBJ 5	Define Pressure and Give Its Units of Measurement	X	X	X
OBJ 6	Describe How to Read a Pressure Gauge	X	X	X
Pneumatic Power				
OBJ 1	Describe the Pneumatic Safety Rules		X	X
OBJ 2	Describe the Basic Operation of a Pressure Regulator Valve		X	X
Skill 1	Connect and Adjust a Pressure Regulator		X	X
OBJ 3	Describe the Basic Operation of a Pneumatic Filter		X	X
Skill 2	Drain a Pneumatic Filter		X	X
OBJ 4	Describe How to Connect an Air Hose with a Quick-Connect Fitting		X	X
Skill 3	Connect a Pneumatic Hose That Uses Quick-Connect Fittings		X	X
OBJ 5	Describe the Operation of Tee and Cross Fittings		X	X
Skill 4	Connect Circuits Using Tee and Cross Fittings		X	X
Basic Cylinder Circuits				
OBJ 1	Describe the Operation of a Double-Acting Pneumatic Cylinder		X	X
Skill 1	Operate a Double-Acting Cylinder		X	X
OBJ 2	Describe the Operation of a 5-Port, 3-Position Directional Control Valve		X	X
Skill 2	Connect and Operate a Double-Acting Pneumatic Cylinder Using a 3-Position, Manually-Operated DCV		X	X
OBJ 3	Describe the Schematic Symbols of Basic Pneumatic Components		X	X
OBJ 4	Describe How to Read and Interpret a Basic Pneumatic Schematic		X	X
Skill 3	Design a Multiple Cylinder Pneumatic Circuit		X	X
OBJ 5	Describe How to Maintain a Fluid Power System		X	X
OBJ 6	Describe the Operation of a Vacuum Lift System		X	X

Objective/Skill/Activity		Applied Math	Graphic Literacy	Workplace Documents
Hydraulic Power				
OBJ 1	Describe the Operation of a Hydraulic Power Unit		X	X
Skill 1	Operate a Hydraulic Power Unit		X	X
OBJ 2	Describe the Function of a Hydraulic Quick-Connect Fitting and Give Its Schematic Symbol		X	X
Skill 2	Connect and Disconnect a Hydraulic Hose That Uses Quick-Connect Fittings		X	X
OBJ 3	Describe How Hydraulic Flow Rate Is Measured	X	X	X
OBJ 4	Describe the Operation of a Fixed-Displacement Gear Pump and Give Its Schematic Symbol		X	X
OBJ 5	Describe the Operation of a Flow Meter and Give Its Schematic Symbol		X	X
Skill 3	Connect and Read a Flow Meter		X	X
Basic Hydraulic Cylinder Circuits				
OBJ 1	Describe the Operation of a Double-Acting Cylinder		X	X
Skill 1	Operate a Double-Acting Hydraulic Cylinder		X	X
OBJ 2	Describe the Function of a 4-Way, 3-Position DCV and Give an Application		X	X
Skill 2	Connect and Operate a Double-Acting Hydraulic Cylinder Using a 3-Position, Manually-Operated DCV		X	X
OBJ 3	Describe the Schematic Symbols of Basic Hydraulic Components		X	X
OBJ 4	Describe How to Read and Interpret a Basic Hydraulic Schematic		X	X
Skill 3	Design a Dual Cylinder Hydraulic Circuit		X	X
Fluid Power Speed Control				
OBJ 1	Describe the Main Function of a Needle Valve		X	X
Skill 1	Connect and Operate a Needle Valve to Control the Speed of an Actuator		X	X
OBJ 2	Describe the Function of a Check Valve and Give an Application		X	X
OBJ 3	Describe the Function of the Flow Control Valve and Give an Application		X	X
OBJ 4	Describe the Operation of a Meter-In Flow Control Circuit and Give an Application		X	X
Skill 2	Connect and Operate a Meter-In Flow Control Circuit		X	X
OBJ 5	Describe the Operation of a Meter-Out Flow Control Circuit and Give an Application		X	X
Skill 3	Connect and Operate a Meter-Out Flow Control Circuit		X	X
OBJ 6	Define Independent Speed Control and Give an Application		X	X

Objective/Skill/Activity		Applied Math	Graphic Literacy	Workplace Documents
Skill 4	Design an Independent Speed Control Circuit		X	X
Fluid Force and Friction				
OBJ 1	Describe How to Calculate the Force Output of an Extending Cylinder	X	X	X
Skill 1	Measure the Force Output of a Cylinder	X	X	X
OBJ 2	Describe Two Types of Resistance in a Fluid Power System		X	X
Skill 2	Measure Delta P across a Fluid Power Component		X	X
OBJ 3	State Pascal's Law and Explain Its Significance in Fluid Power	X	X	X
OBJ 4	Describe the Concept of Fluid Power Leverage	X	X	X
OBJ 5	Describe Absolute and Gauge Units of Pressure Measurement	X	X	X
OBJ 6	Define the Combined Gas Law and Explain Its Importance	X	X	X
OBJ 7	Describe the Factors That Affect Fluid Power Actuator Speed		X	X
Skill 3	Measure Pneumatic Actuator Speed		X	X
Skill 4	Measure Hydraulic Actuator Speed		X	X
Total Productive Maintenance (TPM)				
OBJ 1	Define Total Productive Maintenance and Explain Its Importance			X
OBJ 2	Describe the Principles of Preventive Maintenance		X	X
OBJ 3	Define Predictive Maintenance			X
OBJ 4	Describe the Operation of a Computer-Based Maintenance Management System			X
OBJ 5	Describe Methods of Cleaning Equipment		X	X
OBJ 6	Describe Methods of Eliminating Sources of Contamination in Inaccessible Areas		X	X
OBJ 7	Describe Methods of Equipment Inspection			X
OBJ 8	Define PDCA and Explain Its Importance		X	X